

LED 1CH DIM WALL

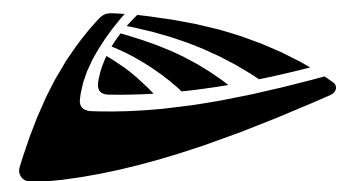

ENGLISH Operation Manual

Other languages can be downloaded from:
WWW.JB-SYSTEMS.EU



Version: 1.0

JB SYSTEMS



EN - DISPOSAL OF THE DEVICE

Dispose of the unit and used batteries in an environment friendly manner according to your country regulations.

FR - DÉCLASSER L'APPAREIL

Débarrassez-vous de l'appareil et des piles usagées de manière écologique Conformément aux dispositions légales de votre pays.

NL - VERWIJDEREN VAN HET APPARAAT

Verwijder het toestel en de gebruikte batterijen op een milieuvriendelijke manier conform de in uw land geldende voorschriften.

DU - ENTSORGUNG DES GERÄTS

Entsorgen Sie das Gerät und die Batterien auf umweltfreundliche Art und Weise gemäß den Vorschriften Ihres Landes.

ES - DESHACERSE DEL APARATO

Reciclar el aparato y pilas usadas de forma ecologica conforme a las disposiciones legales de su país.

PT - COMO DESFAZER-SE DA UNIDADE

Tente reciclar a unidade e as pilhas usadas respeitando o ambiente e em conformidade com as normas vigentes no seu país.

OPERATION MANUAL

Thank you for buying this JB Systems® product. To take full advantage of all possibilities, please read these operating instructions very carefully.

FEATURES

- User-friendly 1Channel wall dimmer for all kinds of 12Vdc / 24Vdc LED-projectors like led strips.
- The included 12-button IR-remote has very easy-to-use features:
 - Remote on/off
 - Delay off: light turns off after 30seconds
 - Seamless 0% - 100% dimming
 - 4 Dimmer hotkeys: 25%, 50%, 75%, 100%
 - 4 User programmable dimmer hotkeys
- PWM technology for smooth and flicker-free dimming from 0% to 100%
- Connects directly to 1color flexible LED-strips and other constant voltage LED-lights.
- Max. output power: 80Watt @12V * 160Watt @ 24V
- Easy wall mounting:
 - Surface-mounted box included
 - Fits in any standard recessed wall box
- Perfect for use in LED installations for homes, shops, ...
- The PWM-output can be used to control dimmable constant current led drivers

BEFORE USE

Check the contents:

Check that the carton contains the following items:

- Wall dimmer LED 1CH DIM WALL
- Surface-mounted box
- IR-remote
- User manual

Some important instructions:

- Before you start using this unit, please check if there's no transportation damage. Should there be any, do not use the device and consult your dealer first.
- **Important:** This device left our factory in perfect condition and well packaged. It is absolutely necessary for the user to strictly follow the safety instructions and warnings in this user manual. Any damage caused by mishandling is not subject to warranty. The dealer will not accept responsibility for any resulting defects or problems caused by disregarding this user manual.
- Keep this booklet in a safe place for future consultation. If you sell the fixture, be sure to add this user manual.
- To protect the environment, please try to recycle the packing material as much as possible.

SAFETY INSTRUCTIONS:



This symbol means: indoor use only



This symbol means: Read instructions



This symbol means: Lamp Control Gear



The device is suitable for mounting on standard flammable surfaces. Standard flammable surfaces include building materials such as wood and wood-based materials more than 2mm thick.

- To prevent fire or shock hazard, do not expose this appliance to rain or moisture.
- To avoid condensation to be formed inside, allow the unit to adapt to the surrounding temperatures when bringing it into a warm room after transport. Condensation sometimes prevents the unit from working at full performance or may even cause damages.
- This unit is for indoor use only.
- Don't place metal objects or spill liquid inside the unit. No objects filled with liquids, such as vases, shall be placed on this appliance. Electric shock or malfunction may result. If a foreign object enters the unit, immediately disconnect the mains power.
- No naked flame sources, such as lighted candles, should be placed on the appliance.
- Don't cover any ventilation openings as this may result in overheating.
- Prevent use in dusty environments and clean the unit regularly.
- Keep the unit away from children.
- Inexperienced persons should not operate this device.
- Maximum safe ambient temperature is 40°C. Don't use this unit at higher ambient temperatures.
- Always unplug the unit when it is not used for a longer time or before you start servicing.
- The electrical installation should be carried out by qualified personal only, according to the regulations for electrical and mechanical safety in your country.
- Check that the available voltage is not higher than the one stated on the rear panel of the unit.
- Please use the original packing when the device is to be transported.
- Due to safety reasons it is prohibited to make unauthorized modifications to the unit.

MAINTENANCE

Clean by wiping with a polished cloth slightly dipped with water. Avoid getting water inside the unit. Do not use volatile liquids such as benzene or thinner which will damage the unit.

ELECTRICAL INSTALLATION

CONNECTIONS FOR SMALLER POWER

This is the typical installation when the power of the connected flexible led strip does not exceed the maximum allowed power of the dimmer. (80W for 12V applications or 160W for 24V applications)

Follow these instructions:

- Calculate the total power of the led strip. The power of led strips is mostly given in watt/meter (W/m).
Example: the power of your ledstrip = 9,6W/m and length = 5m
*The total power = 9,6 W/m * 5m = 48W*
- Choose an adapted power supply based on the previous calculation. For long-term reliability we suggest to add about 20% power reserve and choose the nearest power supply exceeding this calculation.
Example: in our example we need 48W. So we add 20%: 48W + 20% = ±58W
The nearest power supply in this case is our 60W / 24V power supply.
- Connect the power supply output to the Power input of the dimmer. (don't mix-up the polarity of the wires!)
- Connect the led strip to the output of the dimmer. (don't mix-up the polarity of the wires!)
Remark: don't connect more than 5m led strip in series, excessive current will damage the led strip. Instead you can connect the led strips in parallel.
- Switch on the power supply AFTER you checked all connections.
- Done!

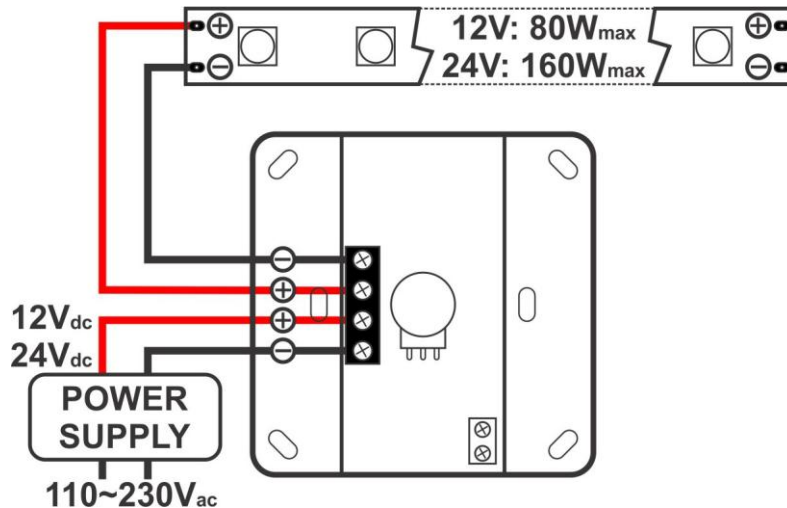

CONNECTIONS FOR BIGGER POWER

This is the typical installation when the power of the connected flexible led strip exceeds the maximum allowed power of the dimmer. (80W for 12V applications or 160W for 24V applications)

Follow these instructions:

- Calculate the total power of the led strip. The power of led strips is mostly given in watt/meter (W/m).
Example: the power of your ledstrip = 14,4W/m and length = 15m
*The total power = 14,4 W/m * 15m = 216W*
- Choose an adapted power supply based on the previous calculation. For long-term reliability we suggest to add about 20% power reserve and choose the nearest power supply exceeding this calculation.
Example: in our example we need 216W. So we add 20%: 216W + 20% = ±260W
The nearest power supply in this case is 2pcs of our 150W / 24V power supply.
- So now we have 2pcs 150W power supply:
 - Power supply1: will be connected directly to the dimmer.
 - Power supply2: will be connected to an LED-REPEATER that will add more power to the led strips.
- Connect the output of power supply1 to the power input of the dimmer. (don't mix-up the polarity of the wires!)
- Connect about 6m led strip (±87W) to the output of the dimmer. Don't mix-up the polarity of the wires!
Remark: don't connect more than 5m led strip in series, excessive current will damage the led strip. Instead you can connect the led strips in parallel.
- Connect the output of power supply2 to the power input of the LED-REPEATER. (don't mix-up the polarity of the wires!)

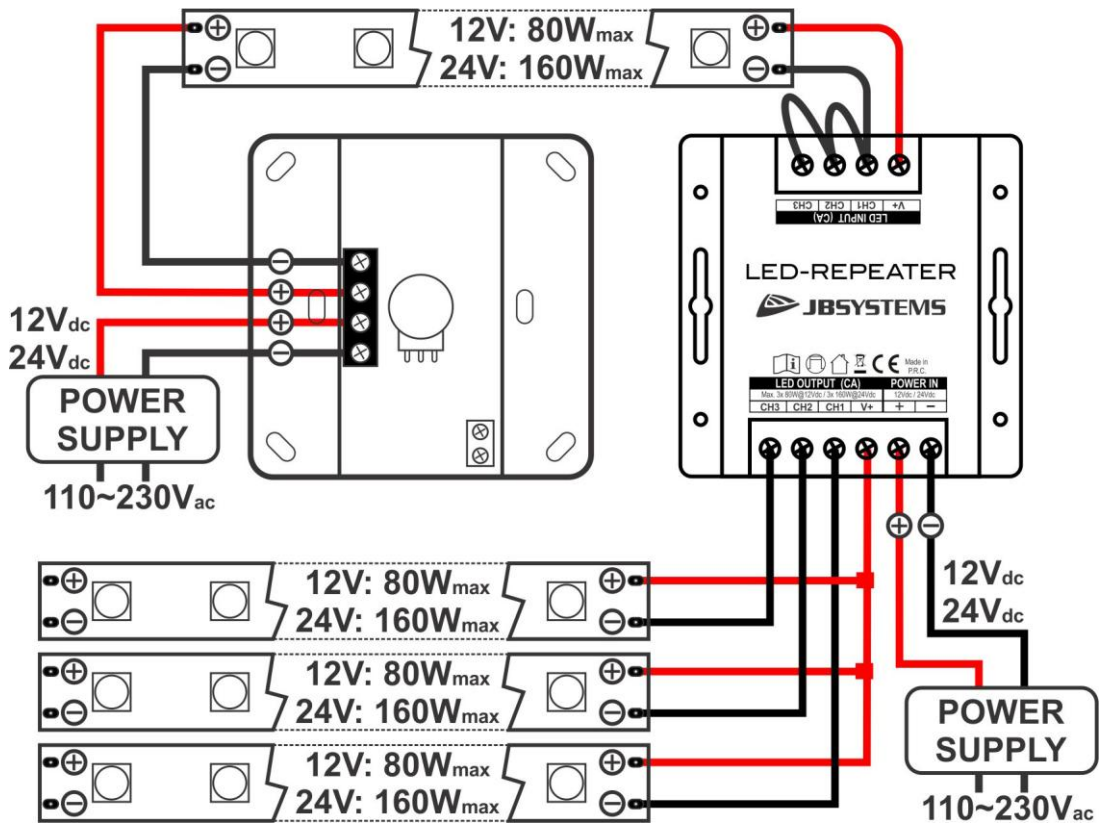

- Connect the output of the dimmer or 6m led strip to the input of the LED-REPEATER. (see drawing)
- Since the LED-REPEATER is designed for use with RGB-led strips, you have to connect the inputs CH1, CH2 and CH3 together. (see drawing)
- Connect the other 9m led strip ($\pm 130W$) to the 3 outputs of the LED-REPEATER: we suggest 3m led strip on each of the 3 outputs. (don't mix-up the polarity of the wires!)
- Switch on the power supply AFTER you checked all connections.
- Done!

SOME GENERAL GUIDELINES

You can make any desired installation BUT you have to keep some important guidelines in mind:

- Calculate the total power of the led strips and add $\pm 20\%$ to determine the power of the power supplies.
- Never connect led strips together in lengths exceeding 5m, instead:
 - Connect the strips in parallel:

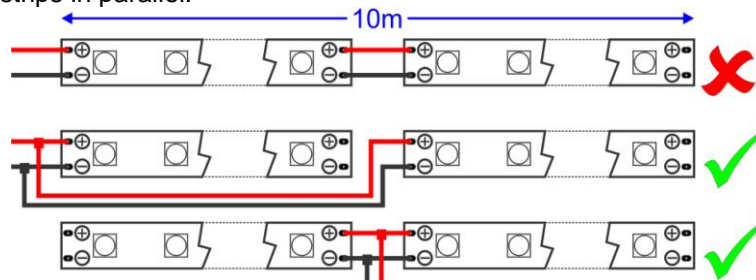

- Use one or more LED-REPEATER + extra power supplies to extend the led strips.
- Use wires with a maximum cable section to reduce important voltage drops. Use at least 1,5mm² wires, for higher power and cable lengths we suggest 2,5mm². Even better is to calculate the voltage drop and use special charts to determine the perfect cable section.

DIMMABLE LED DRIVERS WITH PWM INPUT

Some constant current led drivers can be dimmed using a special PWM-input. For these LED drivers you can use the special PWM output on the dimmer. For more information: see the LED driver.

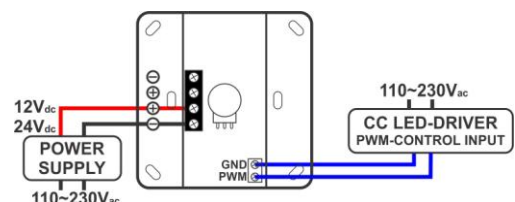

MECHANICAL INSTALLATION:

- Take the cover plate off (easy click-on system)
- Put the unit in the surface-mounted (or standard recessed) wall box

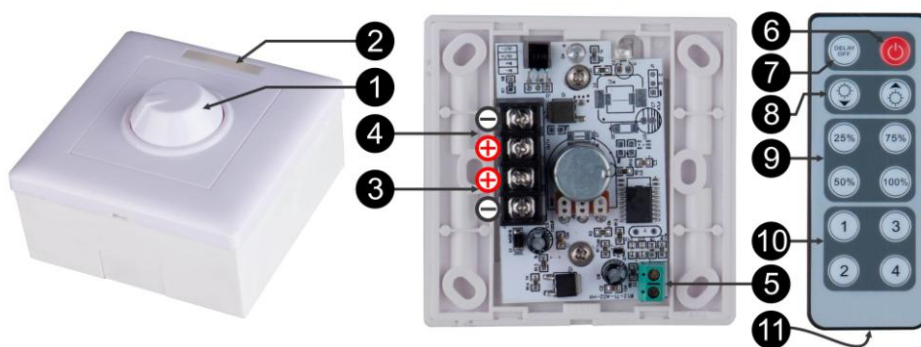

- Fasten with the 2 screws that came with the dimmer.
- Click the cover plate back on.

FUNCTIONS

- DIMMER KNOB:** used to manually adjust the output from 0% to 100%. The position of the knob is not relevant while the IR-remote is used.
- IR-RECEIVER:** receives the IR-light from the IR-remote, don't cover this area.
- POWER INPUT:** connect the power supply (12Vdc or 24Vdc) here (check the polarity !)
- LOAD OUTPUT:** connect the led strip(s) here (check the polarity !)
- PWM OUTPUT:** used to dim certain dimmable led drivers (see led driver instructions)
- ON/OFF BUTTON:** used to switch the output on/off
- DELAY-OFF BUTTON:** after pressing this button the light will be softly dimmed after ± 30 seconds.
- BRIGHTNESS \pm BUTTONS:** Press these buttons to adjust the brightness very accurately.
- FACTORY DIMMER PRESETS:** select one of the 4 preset dimmer levels (25%, 50%, 75% or 100%)
- USER DIMMER PRESETS:** can be programmed at any desired dimmer level:
 - Programming:**
 - Set the desired dimmer level using the BRIGHTNESS \pm buttons (5)
 - Press one of the 4 USER PRESET buttons (7) for about 3seconds: the output will flash shortly to indicate that the setting was saved.
 - Recall a preset:**
 - Simply press one of the 4 USER PRESET buttons (7) shortly.
- BATTERY COMPARTMENT:** houses a 3V-battery (type: CR-2025)

SPECIFICATIONS

This unit is radio-interference suppressed. This product meets the requirements of the current European and national guidelines. Conformity has been established and the relevant statements and documents have been deposited by the manufacturer.

Power Input:	12Vdc or 24Vdc (depends on the voltage of the led strips)
Output:	1ch common anode, 80W @ 12Vdc or 160W @ 24Vdc
Dimensions (HxWxD):	87 x 87 x 53 mm (incl. knob and surface-mount box)
	87 x 87 x 15 mm (min. installation depth for recessed wall box)
Battery IR-remote:	3V-battery (type: CR-2025)
Weight:	150 g

Every information is subject to change without prior notice

You can download the latest version of this user manual on our website: www.jb-systems.eu



JB SYSTEMS

MAILING LIST

EN: Subscribe today to our mailing list for the latest product news!

FR: Inscrivez-vous à notre liste de distribution si vous souhaitez suivre l'actualité de nos produits!

NL: Abonneer je vandaag nog op onze mailinglijst en ontvang ons laatste product nieuws!

DE: Abonnieren Sie unseren Newsletter und erhalten Sie aktuelle Produktinformationen!

ES: Suscribete hoy a nuestra lista de correo para recibir las últimas noticias!

WWW.JB-SYSTEMS.EU

Copyright © 2016 by BEGLEC NV

t Hofveld 2C ~ B1702 Groot-Bijgaarden ~ Belgium

Reproduction or publication of the content in any manner, without express permission of the publisher, is prohibited.