

ISA One

User Guide

Warnings & Cautions

THE APPARATUS SHALL NOT BE EXPOSED TO DRIPPING OR SPLASHING, AND NO OBJECTS FILLED WITH LIQUIDS, SUCH AS VASES, SHALL BE PLACED ON THE APPARATUS

VENTILATION SHALL NOT BE IMPEDED BY COVERING THE VENTILATION OPENINGS WITH ITEMS, SUCH AS NEWSPAPERS, CLOTHS, CURTAINS ETC.

NO NAKED FLAME SOURCES, SUCH AS LIGHTED CANDLES, SHOULD BE PLACED ON THE APPARATUS

MAINS LEAD - THIS EQUIPMENT MUST BE EARTHED AND FITTED WITH THE CORRECT LEAD FOR THE COUNTRY OF OPERATION. THIS WILL NORMALLY BE ACHIEVED FROM THE CORRECT MAINS SUPPLY SOCKET

DO NOT USE A DAMAGED OR FRAYED POWER CORD

IF THE MAINS PLUG SUPPLYING THIS APPARATUS INCORPORATES A FUSE THEN IT SHOULD ONLY BE REPLACED WITH A FUSE OF IDENTICAL OR LOWER RUPTURE VALUE

SHOULD THE APPARATUS OR SUPPLY CORD BECOME PHYSICALLY DAMAGED THEN IT SHOULD NOT BE POWERED, AND ADVICE SHOULD BE SOUGHT FROM SUITABLY QUALIFIED PERSONNEL

THIS UNIT MUST BE EARTHED BY THE POWER CORD

UNDER NO CIRCUMSTANCES SHOULD THE MAINS EARTH BE DISCONNECTED FROM THE MAINS LEAD

This unit is capable of operating over a range of mains voltages as marked on the rear panel. Ensure correct mains voltage setting and correct fuse before connecting mains supply. Do not change mains voltage settings while mains supply is connected. To avoid the risk of fire, replace the mains fuse only with the correct value fuse, as marked on the rear panel. The internal power supply unit contains no user serviceable parts. Refer all servicing to a qualified service engineer, through the appropriate Focusrite dealer.

Contents

1. Warnings and Cautions	2
2. Contents	3
3. Getting Started and Powering Up	3
4. Front Panel	4
4.1 Metering	7
5. Rear Panel	8
6. Digital Options	9
7. Recording a Microphone	12
8. Recording a Line-level source	13
9. Recording an Instrument	13
10. Two-channel Recording Options	13
11. Monitoring Options	14
12. Applications	14
12.1 Mic Preamp Input Impedance	14
12.2 Signal Connections.....	16
13. Specifications.....	17
14. Warranty.....	19

Getting Started and Powering Up

The ISA One is a high quality preamplifier, which can be used to record microphone, line-level or instrument sources. Microphones and line-level sources are connected on the rear panel, whilst instruments are plugged directly into the front panel. The front panel also features gain controls and other settings such as phantom power and input impedance. A traditional moving-coil VU and an LED peak meter are provided, both with a dial on the rear panel for calibration, to ensure a suitable signal level is achieved.

If wanting to maintain pristine Focusrite quality in the digital domain, an optional digital output card can be installed, for connecting an AES, S/PDIF or ADAT™ signal directly to the DAW. With the card fitted, the clock sample rate and sync source can be selected using switches on the front panel.

A 2-way switch on the rear panel, labelled Power, supplies power to the unit, providing the supplied IEC mains lead is connected to the socket below. Make sure that the ISA One is turned on before powering up any devices connected to the outputs.

The IEC mains lead supplied with the unit should have the correct moulded plug for your country. The wiring colour code used is:

For units shipped to the USA, Canada, Taiwan and Japan:

Live - Black; Neutral - White; Earth – Green

For units shipped to any other country:

Live - Brown; Neutral - Blue; Earth - Green and Yellow

Front Panel



1. Gain dial: selects the gain of the input in stepped values of 10
2. Trim dial: allows an additional 20dB of gain to be applied to a mic or line signal
3. Activates a gain range of 30-60dB across the stepped Gain dial (the default is 0-30dB)
4. Phantom Power switch: supplies +48V to the MIC input on the rear panel
5. Inverts the phase of the signal
6. Activates a high-pass filter
7. Allows the signal to be sent to additional processors (via the send and return on the rear panel) before converting to digital
8. Selects the type of input
9. Sets the Mic input impedance to 600Ω (Low), 1k4Ω (ISA 110), 2k4Ω (Med) or 6k8Ω (High)
10. Sets the instrument input impedance to 470kΩ or 2.4MΩ
11. Instrument Gain Dial: sets the gain of the instrument (connected to DI) to between 10 and 40dB
12. Allow an instrument to be connected directly (DI) and then sent back to an amp (Amp)
13. Allows calibration of the VU meter using the rear panel dial
14. Moving-coil VU meter: displays the average level of the main input signal
15. Displays the input signal after the insert (return signal) on the VU meter and the first peak meter when pressed
16. Peak LED meters: show the main input (left meter) and either the instrument input (DI) or the EXT IP levels (right meter). These are the 2 inputs into the optional ADC
17. TRS socket for connecting headphones
18. Gain dial for any connected headphones
19. Sends the cue mix, connected to the rear panel inputs, to the headphones when active
20. Selects the sample rate
21. Selects the ADC to lock to an external source connected to the word clock input on the rear panel (either standard word clock or 256x)
22. Lock LED indicates when a successful synchronisation is achieved

Input

Pressing INPUT steps through each of the three inputs, as indicated by the corresponding LEDs. When the Mic LED is lit, the microphone input is active etc. An XLR input for a microphone, as well as both XLR and TRS 1/4" inputs for line-level sources, can be found on the rear panel. A TS 1/4" input for an instrument (DI) is available on the front panel.

Mic input gain

With the Mic input selected, the user has access to the full gain range in 10dB steps from 0dB to +60dB (yellow legend). The gain range is split between two gain modes depending upon the status of the 30-60 switch.

Mode 1: Mic Gain Range 0-30

With the 30-60 switch off, the stepped gain dial operates over a gain range of 0dB to +30dB, the level of gain chosen being indicated on the front panel by the outer arc of yellow numbers around the gain knob.

Mode 2: Mic Gain Range 30-60

With the 30-60 switch on (illuminated), the stepped gain dial operates over a gain range of 30dB to 60dB, the level of gain chosen being indicated on the front panel by the outer arc of yellow numbers around the gain knob.

An additional 20dB of gain can be applied to the signal after the mic/line stepped Gain knob using the smooth rotation Trim knob. (See the 'Trim' control text below for a full explanation.)

Line input gain

With the line input selected, the user has access to gain settings ranging from -20dB to +10dB, indicated on the front panel by the arc of white numbers around the stepped gain knob. The 30-60 switch is inactive when the line input is selected, as the gain range for line-level inputs is restricted to -20dB to +10dB in 10dB steps. An additional 20dB of gain can be applied to the signal after the stepped mic/line gain knob using the smooth rotation Trim knob. (See the 'Trim' control text below for a full explanation.)

Instrument input gain

With the instrument input selected, gain is applied to the input signal by using the Instrument Gain dial, which allows +10dB to +40dB of gain range. The level of gain chosen is indicated on the front panel by the arc of white numbers around the gain knob. This input is suitable for high impedance sources such as guitar or bass pickups (which may be connected directly without the need for an external DI box) or vintage synthesizers with high impedance outputs.

Trim

The Trim control provides additional variable gain of 0dB to +20dB when mic or line inputs are selected. The level of trim chosen is indicated on the front panel by the arc of white numbers around the trim knob. The additional 20dB of gain that can be applied to the mic or line signal is very useful for two reasons:

When high gain is required

Using trim in conjunction with the mic gain of 60dB gives a total of up to 80dB of pre-amp gain, making it very useful for getting good digital recording levels from very low output dynamic and ribbon microphones.

Gain adjustment during recording

When small amounts of gain adjustment are needed to correct performance level variations during recording, use the trim knob rather than the stepped mic/line gain knob, as switching the 10dB gain steps would be much too intrusive. It is therefore good practice to apply some Trim gain before using the 10dB stepped gain knob to find the optimum recording level so that the Trim control can be used to gently add or take away gain later, if so required.

+48V

Pressing the +48V switch provides phantom power, suitable for condenser microphones, to the rear panel XLR microphone connector. If you are unsure whether your microphone requires phantom power, refer to its handbook, as it is possible to damage some microphones (most notably ribbon microphones) by providing phantom power.

Phase

Pressing PHASE inverts the phase of the selected input to correct phase problems when using multiple microphones, or when incorrect wiring polarity has occurred.

Insert

Activating the INSERT switch (illuminated when active) breaks the signal path of the channel, so that the signal sent to the first ADC Input and the analogue output on the rear panel is the signal received at the INSERT RETURN connector (on the rear panel) rather than the direct mic, line or instrument signal. This switch is designed to allow the input signal to be routed to other hardware for processing and then back into the ISA One for digital conversion. The POST INSERT switch on the front panel allows the 'return' signal level to be viewed on the left-hand LED peak meter before conversion (see the Metering section on the next page for details).

HPF

Pressing the HPF switch makes the High Pass Filter active in the audio path. This is useful for removing any unwanted bass caused by proximity effect or rumble. The filter provides a 75Hz knee frequency with 18dB/octave roll-off.

Z In (Input Impedance)

Pressing the Z In switch steps through each of the four transformer preamp input impedance values, as indicated by the corresponding LEDs. By selecting different values for the impedance of the ISA One transformer input, the performance of both the ISA One preamp and the microphone connected can be tailored to set the desired level and frequency response. The impedance values are as follows:

Low – 600Ω, ISA 110 – 1k4Ω, Med – 2k4Ω, High – 6k8 Ω

A guide to setting input impedance is available in the Applications section.

Instrument input impedance

The Instrument Z In switch toggles between High and Low impedance settings for the instrument input. (These settings have the same effect on signal level and frequency response as outlined in the input impedance explanation in the Applications section.) The impedance values are as follows:

Low – 470kΩ, High – 2.4MΩ

Instrument i/o (DI and AMP)

The two connectors in the Instrument section on the front panel, labelled DI and Amp, are for connecting a guitar or bass directly and then sending back to an amplifier. The left unbalanced/TS connector (DI) is therefore an input for receiving the direct guitar signal, whilst the right unbalanced/TS connector (Amp) is an output for linking back to a guitar amp. The rear panel DI OUT connector can then feed the instrument signal to an external recording medium or audio interface. This facility can be used even if a microphone or line-level signal is being recorded simultaneously (see the Two-channel Recording Options for details). See the Recording an Instrument section for more details about using a guitar with ISA One.

Phones

The socket labelled phones allows a pair of headphones with a TRS ¼" Jack plug to be connected to ISA One. When in the default state (the CUE MIX button is not lit), the signal received in the headphones is the input or inputs connected to ISA One. This will normally be simply a mic, line or instrument signal selected by the INPUT switch. However, in a situation where an instrument and a mic or line are in use, or a mic/line and an external signal (connected to the rear panel), a non-adjustable mix of all inputs will be heard. For more information on two-channel recording and monitoring options, see the Applications section.

With the CUE MIX button active, the signal sent to the headphones is the one received at the CUE MIX INPUTS on the rear panel. See the next section for details.

The Volume dial to the right can be used to set the level of the signal in the headphones, once the relevant source is selected.

Cue mix

Activating the CUE MIX button sends the signal connected to the rear panel CUE MIX INPUTS to the headphones. When in cue mix mode, no inputs can be heard in the headphones. This facility means that, in a low latency environment, a monitor mix can be fed from a desk into ISA One to provide a suitable cue mix for the recording artist.

Although ISA One has no monitor mixing capabilities, there is one method that allows an engineer working in a higher latency environment (with a DAW) to create a blend of inputs and outputs for headphones. The EXT I/P connector on the rear panel provides an input for a mono signal, intended primarily to gain access to the second input channel on the optional ADC card, but also offering some monitoring functionality. One channel of a master mix can be sent from music software (via an audio interface or sound card) to the external input (EXT IP) of ISA One, which will then be panned centrally, along with the mic/line/inst input signal and sent to the headphones. Note that the CUE MIX button should be inactive in this mode. For more information on creating a cue mix in a higher latency environment, read the Monitoring Options section.

Metering

ISA One's front panel offers a variety of metering options so that the levels of any inputs can be viewed. A traditional moving-coil VU meter provides an average level reading for the main input signal (whatever is selected by the INPUT switch). Meanwhile, to the right, two vertical LED meters display the peak level of the same signal (that selected by the INPUT switch) on the left meter, and either an instrument connected to the DI INPUT or the signal received at the EXT I/P on the right meter. The signals shown by the LED meters relate to the two signals being sent to the optional ADC, if installed. These signals default to the main mic/line/inst input and the DI input, respectively, but become the main mic/line/inst input and the external input if a signal is connected to the EXT I/P socket on the rear panel.

There are two states for the VU meter and the left LED meter, set by the POST INSERT switch:

Default mode

With the POST INSERT switch inactive (not lit), the signal displayed on the VU meter and the left LED meter is the main mic/line/inst signal selected by the INPUT switch, just after the input circuitry (gain, phase, high-pass filter etc.) but before the Insert. This is the signal sent to the MAIN O/P and channel 1 of the optional ADC (if installed), when the INSERT switch on the front panel is not active (not lit).

Post Insert mode

With the POST INSERT switch active (lit), the signal displayed on the VU meter and the left LED meter is the signal received at the INSERT RETURN socket on the rear panel. This is the signal sent to the MAIN O/P and channel 1 of the optional ADC (if installed), when the INSERT switch on the front panel is active (lit). Use this mode when you are sending the main mic/line/inst signal to an external processor, via the INSERT SEND and RETURN, before returning to the ISA One for monitoring or conversion.

Calibration

Both the VU meter and the LED meters can be calibrated using the two corresponding dials on the rear panel (see the Rear Panel section for the exact location). This allows a more suitable range for the meters, so that the signal being recorded can be displayed in an appropriate way. A low level signal, for example, will not display much activity on the meters, which can be rectified by reducing the dBu level represented by 0VU (VU meter) or 0dBFS (LED meters). The meters are calibrated in the following way:

VU Meter

If wanting to calibrate the VU meter, the VU CAL switch on the front panel must first be activated. Once the VU CAL switch has been pressed and is lit, the VU METER CAL dial on the rear panel can be rotated to change the dBu level represented by 0VU. In default mode, with the VU CAL switch inactive (not lit), 0VU is equal to +4dBu. Activating the VU CAL switch allows the VU METER CAL dial to set a new value for 0VU from +11dBu (fully anticlockwise) to +26dBu (fully clockwise). There is a centre detent in the VU METER CAL dial, at which 0VU is equal to +22dBu.

LED Meters

If wanting to calibrate the LED meters, the PEAK METER CAL dial on the rear panel can be used. In the default state, with the dial in a central ('detented') position, 0dBFS is equal to +22dBu. Rotating the dial in either direction sets a new value for 0dBFS from +18dBu (fully anticlockwise) to +26dBu (fully clockwise).

Rear panel



1. Optional ADC (digital conversion card)
2. Microphone (XLR) Input
3. Line-level (XLR) Input
4. Line-level (TRS 1/4" Jack) Input
5. Outputs the main mic/line/inst input signal, as selected by the INPUT switch on the front panel
6. Outputs the instrument signal connected to the DI Input on the front panel (regardless of whether INST is selected using the INPUT switch)
7. Calibrates the Peak Meters (see the previous section for details)
8. Transmits (SEND) and receives (RETURN) the main mic/line/inst input for additional signal processing. The INSERT switch on the front panel should be active when in use. Both connectors are 1/4" TRS Jack
9. Allows an external mono signal to be connected using a 1/4" TRS Jack, for monitoring or converting to digital format
10. Allows an external stereo signal to be connected using two 1/4" TRS Jacks, providing a monitor mix for a recording artist
11. Calibrates the VU Meter (see the previous section for details)
12. Mains IEC connector
13. Power switch

Analogue inputs

The MIC I/P (XLR) and LINE I/Ps (XLR and ¼" TRS Jack) can be used to connect an analogue source to ISA One. If a microphone is connected to the MIC I/P, phantom power can also be supplied by making sure MIC is selected using the INPUT switch on the front panel, then activating the +48V switch. If you are unsure whether your microphone requires phantom power, refer to its handbook, as it is possible to damage some microphones (most notably ribbon microphones) by providing phantom power.

If wanting to record a Line-level signal then you have the choice of using an XLR or balanced Jack connector. Once connected, simply use the INPUT switch on the front panel to select LINE.

The remaining analogue inputs are for an external mono signal (EXT I/P) and stereo signal (CUE MIX LEFT/RIGHT). The mono signal connected to EXT I/P is summed with the main input signal and sent to the headphones for monitoring, as well as being sent independently to the second channel of the optional ADC, if installed. (See the Digital Options or Monitoring Options sections for details.) The stereo signal connected to CUE MIX can be routed to the headphones by activating the CUE MIX switch on the front panel. (See the Monitoring Options section for details.)

Analogue outputs

There are two analogue outputs on the rear panel of ISA One. The MAIN O/P (channel 1) and the DI O/P (channel 2). The first channel relates to the main input signal being processed, and is selected using the INPUT switch on the front panel. The second channel is always the instrument signal that is connected to the DI input on the front panel.

Insert

The two INSERT connectors are for sending and returning the main mic/line/inst signal to and from an additional processor, like a compressor. Connect SEND to the input of the additional processor and RETURN to its output, preferably with balanced cables as both inputs are ¼" TRS Jack. Make sure that the INSERT switch is activated on the front panel if using the Insert facility, so that the RETURN signal is routed to the meters (with the POST INSERT switch engaged), MAIN O/P and channel 1 of the optional ADC (if installed). For more information on using the ISA One Insert, see the INSERT section in the Front Panel Overview.

Digital options

ISA One can be used as a high quality two-channel ADC to convert analogue signals to various digital formats (AES, S/PDIF and ADAT), by installing the optional digital output board (ADC). The optional ADC can be retrofitted to a standard ISA One at any time. No engineering experience is required as the card can be fitted easily by the user. Full fitting instructions for this option are included along with the ADC.



1. Word clock In and Out (BNC connectors)
2. Optical/TOSLink Digital Outputs (ADAT and S/PDIF)
3. AES or S/PDIF Select Switch for the 9-pin Digital Output
4. 9-pin Digital Output (AES or S/PDIF, selected by the adjacent switch)
5. Selects 1-wire or 2-wire mode across the 9-pin Output to allow ISA One to be connected to older digital equipment

The optional ADC can convert two separate channels of audio. The second of the two channels received at the ADC Input is determined by a connection on the rear panel. With no signal connected to EXT I/P, the second channel is fed from the DI (Instrument) input on the front panel. Connecting a signal to EXT I/P makes that signal replace the instrument as the second channel going into the ADC. The first channel, however, will always be the main mic/line/inst input selected by the INPUT switch on the front panel. The LED meters on the front panel can be used to view the levels of the two channels received at the ADC input.

Digital formats available on the ADC are AES, S/PDIF (optical and coaxial) and ADAT™ optical format. (The ADAT™ output can also operate in high-speed SMUX mode for 96kHz transfer speeds, but is muted during 192kHz operation.) N.B. If RCA phono (S/PDIF) or XLR (AES) connections are required, the relevant 9-pin D-type to RCA phono or XLR breakout cable is required (see below).

24-bit/96kHz ADAT™ or 24-bit/192kHz S/PDIF (optical/ lightpipe) interface operation

The card provides optical digital outputs for both ISA One ADC input channels, which operate over the sample frequency ranges 44.1, 48, 88.2 and 96kHz (ADAT™) and also 176.4 and 192kHz (S/PDIF). The card features an ADAT™-type 'lightpipe' output and S/PDIF Toslink output connectors. ADAT™ lightpipe cables are available from your local dealer, or in the UK from Studiospares (tel +44 (0)20 7482 1692): stock number 585-510.

24-bit/192kHz AES or S/PDIF operation (9-pin)

The card also provides AES and S/PDIF format outputs via a 9-pin D-type connector on the rear panel. The full range of sample rates up to 192kHz are available. To access the digital signals from the 9-pin D-type output connector, the A/D card must be purchased with either an AES or S/PDIF D-type conversion cable as follows:

AES cable: 9-pin D-type to 4 male XLR, S/PDIF cable: 9-pin D-type to 4 male RCA phono

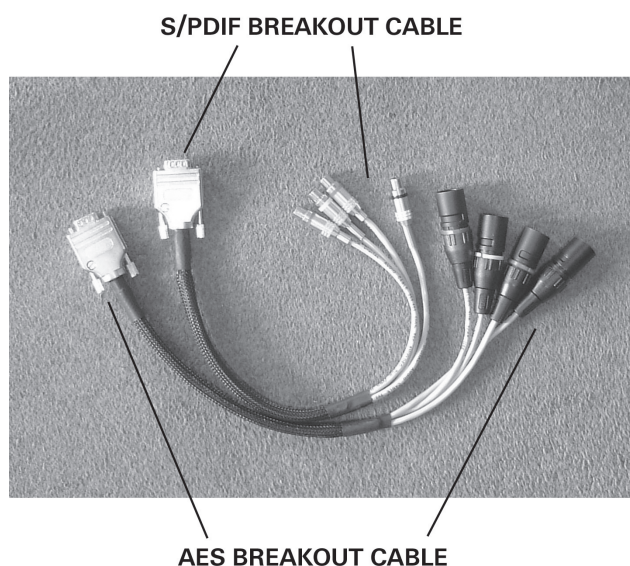

Note: cables need to be purchased separately. Since there are two different cable options – XLR for AES and RCA phono for S/PDIF – these are not included with the A/D converter options. Focusrite cables may be purchased from your local dealer. If you experience difficulty in obtaining these cables, contact your local distributor as listed in the back of this User Guide.

AES/SPDIF Connector Configuration

The 9-pin D-type connector labeled AES/SPDIF can be configured either as an AES or S/PDIF dedicated output using the AES/SPDIF switch next to it. When operating the connector in AES mode, an AES cable is required. When operating in S/PDIF mode, the S/PDIF RCA cable should be used, which automatically sets the output stream to consumer mode.

The 1 Wire/2 Wire switch selects 1-wire or 2-wire mode for the AES output as follows:

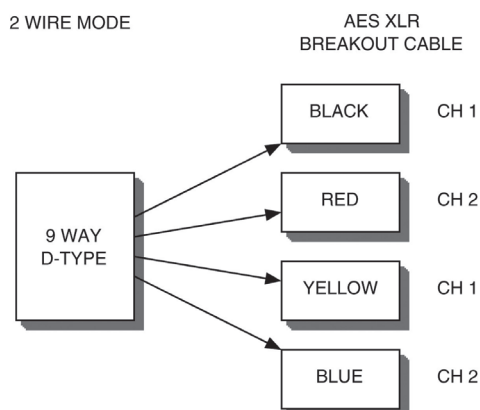
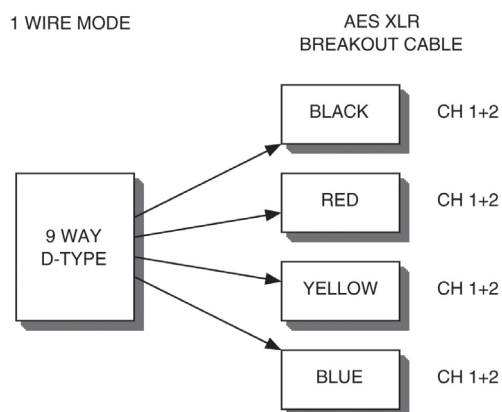

1-wire mode

Selected with the switch in the 'out' position. The AES connector transmits two channels of AES data simultaneously for all sample frequencies from 44.1 to 192kHz, over a single wire.

2-wire mode

Selected with the switch in the 'in' position. The AES connector transmits one channel of AES data only per cable, for all sample frequencies from 96kHz to 192kHz. The reason for the two modes is that older equipment with 96kHz and 192kHz AES inputs can only receive speeds up to 192kHz by using both digital channels of a single AES connection (known as '2-wire'). Therefore, one AES channel can send only a single channel of digital data. This switch makes the ISA One useable with both old and new equipment.

Word Clock In and Out

The internal ADC can be synchronised to an external word clock. By pressing the front panel EXT sync switch, the ISA One can be switched to lock to either standard external word clock or 256x external word clock. Either type of external word clock should be connected to the ISA One ADC card at the WORD CLOCK IN BNC connector on the rear panel.

The WORD CLOCK OUT BNC connector either regenerates the external word clock connected at the word clock input connector (if locked to an external clock source) or transmits the internal sample frequency of the ADC card (if the ISA One is acting as word clock master). Where the ISA One is being used as a slave device within a larger digital system, the WORD CLOCK OUT BNC connector can be used to pass on the external word clock signal to the next device. When the unit is not slaved to another device and is in internal clock mode, the word clock output connector outputs the sample frequency selected on the ISA One front panel (see next section).

Digital Output Front Panel Controls

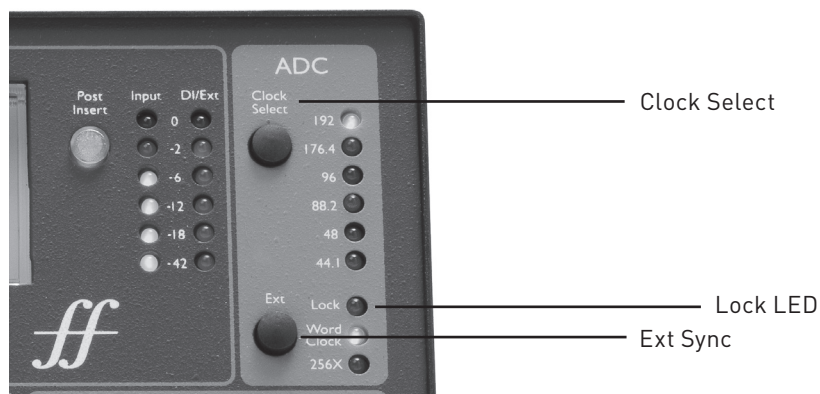

Clock Select

Pressing this switch allows you to select between sample frequencies of 44.1kHz, 48kHz, 88.2kHz, 96kHz, 176.4kHz, and 192kHz.

EXT

Pressing EXT allows the ISA One to be slaved to an external word clock source. Selecting 256X allows the ISA One to be slaved to an external clock running at 256 times faster than the sample frequency and enables connection to systems such as the Digidesign 'Superclock' or other 256X master clock devices.

Lock LED

When lit, LOCK indicates that ISA One is synchronised to an external word clock source.

Note: The LOCK LED does not light when synchronised to 256X, if digital audio is coming out of the ADC when synchronising to 256X it is locked.

Recording a microphone

To record a microphone signal with ISA One, carry out the following steps:

1. Connect the microphone using an XLR cable, to the MIC I/P on the rear panel
2. Select MIC as the input source using the INPUT switch
3. If required, activate phantom power using the +48V switch. If you are unsure whether your microphone requires phantom power, refer to its handbook, as it is possible to damage some microphones (most notably ribbon microphones) by providing phantom power
4. Set the gain of the microphone using the two dials on the front panel and observing the VU meter or left hand LED meter. The stepped gain sets the level in 10dB steps, with the Trim dial adding a further 20dB on top. If the level is too low, use the 30-60 switch to add 30dB to the gain range
5. Use the left-hand Z IN switch to adjust the input impedance if wanting to obtain more level or change the frequency response (see the Mic Preamp Input Impedance section for details)
6. Activate the HPF and Phase reverse switches if required (consult the Front Panel section for details)

The microphone signal will then be sent to the MAIN O/P on the rear panel, as well as to the first channel of the ADC (if installed).

Recording a line-level source

To record a line-level signal with ISA One, carry out the following steps:

1. Connect the line-level signal, using either an XLR or a ¼" TRS Jack cable, to the appropriate LINE I/P on the rear panel
2. Select LINE as the input source using the INPUT switch
3. Set the gain of the line signal using the two dials on the front panel and observing the VU meter or left-hand LED meter. The stepped gain dial sets the level in 10dB steps, with the Trim dial adding a further 20dB on top

The line-level signal will then be sent to the MAIN O/P on the rear panel, as well as to the first channel of the ADC (if installed).

Recording an instrument

To record a guitar or bass with ISA One, carry out the following steps:

1. Plug the instrument directly into the DI input on the front panel
2. Connect the AMP output on the front panel to your guitar amp if one is in use
3. Set the gain of the instrument using the GAIN dial
4. Use the right-hand Z IN switch if wanting to obtain more or less level or high frequency from the instrument (see the Mic Preamp Input Impedance section for details)

Even with MIC or LINE selected by the INPUT switch, the (direct) instrument signal will then be sent to the DI O/P on the rear panel (this is always the case, regardless of settings), as well as to the second channel of the ADC (if installed). Without INST selected by the INPUT switch, the level of the instrument can be viewed on the right-hand LED meter. If wanting to record the direct and amplified guitar, a microphone can then be used simultaneously with ISA One for that purpose (see the next section for details).

Select INST using the INPUT switch if wanting to route the instrument signal through ISA One's main recording path. The benefits of this include:

- The Insert can be used to add effects and additional processing
- The VU meter can be used to view the signal, in addition to the LED meters
- The EXT I/P can be used for monitoring and digital conversion
- Clean and effected versions of the instrument can be recorded using the DI and MAIN outputs, respectively

Two-channel recording options

ISA One can be used to record an instrument and a mic or line signal simultaneously. This is because, with MIC or LINE selected using the INPUT switch on the front panel, an instrument connected to the DI Input will still be fed to the DI O/P (on the rear panel) and to the ADC (if installed and nothing is connected to the EXT I/P).

For example, a recording setup that uses this could be one where a guitar player and vocalist are to be recorded at the same time. In this instance, the vocal would be recorded using a microphone connected to the MIC XLR Input on the rear panel, with MIC selected using the INPUT switch on the front panel. This signal is then sent to a recording medium using either the MAIN O/P on the rear panel or an output on the optional ADC (if installed).

At the same time, the guitarist could be plugged in directly to the DI Input on the front panel. The guitar signal (now balanced and with lower output impedance) can then also be sent to a recording medium, this time from the DI O/P on the rear panel.

If only wanting to record guitar then this 2-channel facility can be used in a similar way. Only, in this instance, the AMP Output on the front panel is used to feed the direct instrument signal back into the amplifier, and the microphone is used to record the amplified guitar. This way, the clean direct guitar and the amplified guitar can be recorded on separate tracks (see diagram 3 in the Signal Connections section).

Monitoring Options

ISA One offers a variety of monitoring options from the PHONES section on the front panel. If wanting to access the monitoring facility, connect a pair of headphones to the PHONES socket using a ¼" TRS Jack connector, then use the VOLUME control to set the level. There are two basic monitoring modes, one for listening to the inputs and one for listening to a monitor mix sent to ISA One from a desk or similar source. These modes are governed by the status of the CUE MIX switch, as follows:

Default Mode (CUE MIX switch inactive/not lit)

The signal sent to the headphones is a fixed mix of all inputs, e.g. the main mic/line/inst input and either the DI instrument signal or the EXT I/P signal. So, if a microphone is connected to the rear panel and selected by the INPUT switch, whilst a guitar is plugged into the DI input on the front panel, a mix of the microphone signal and the direct guitar will be heard in the headphones.

Cue Mix Mode (CUE MIX switch active/lit)

Pressing the CUE MIX button activates a mode where the signal heard in the headphones is that connected to the CUE MIX I/Ps on the rear panel. This is a useful mode if using ISA One with a desk, where a master mix of backing tracks and the signal being recorded can be sent back to ISA One for monitoring. If working in a higher latency environment such as with a DAW, the default mode (CUE MIX switch inactive) can be used to create a latency free monitor mix, as described below.

Creating a latency-free monitor mix with a DAW

The default mode described above can be used to create a latency-free monitor mix if using ISA One with a DAW, where attempting to monitor the signal being recorded after sending through the host creates timing problems. In this situation, a mono master mix from your music software can be sent to ISA One by connecting the left or right output of your soundcard or interface to the EXT I/P on the rear panel. This signal will replace the DI input on the front panel as the second input sent to monitoring and to the ADC (if installed). A mix of the main mic/line/inst input and the EXT I/P (both panned centrally) can then be listened to on the headphones (with the CUE MIX switch inactive) for latency-free monitoring. See diagram 2 in the Signal Connections section for more details.

Applications

Mic Preamp Input Impedance

A major element of the sound of a mic pre is related to the interaction between the specific microphone being used and the type of mic preamp interface technology it is connected to. The main area in which this interaction has an effect is the level and frequency response of the microphone, as follows:

Level

Professional microphones tend to have low output impedances and so more level can be achieved by selecting the higher impedance positions of the ISA One mic preamp.

Frequency response

Microphones with defined presence peaks and tailored frequency responses can be further enhanced by choosing lower impedance settings. Choosing higher input impedance values will tend to emphasise the high frequency response of the microphone connected, allowing you to get improved ambient information and high end clarity, even from average-performance microphones. Various microphone/ISA One preamp impedance combinations can be tried to achieve the desired amount of colouration for the instrument or voice being recorded. To understand how to use the impedance selection creatively, it may be useful to read the following section on how the microphone output impedance and the mic preamp input impedance interact.

Switchable Impedance: In Depth Explanation

Dynamic moving coil and condenser microphones

Almost all professional dynamic and condenser microphones are designed to have a relatively low nominal output impedance of between 150Ω and 300Ω when measured at 1kHz. Microphones are designed to have such low output impedance because the following advantages result:

- They are less susceptible to noise pickup
- They can drive long cables without high frequency roll-off due to cable capacitance

The side effect of having such low output impedance is that the mic preamp input impedance has a major effect on the output level of the microphone. Low preamp impedance loads down the microphone output voltage, and emphasizes any frequency-related variation in microphone output impedance. Matching the mic preamp resistance to the microphone output impedance (e.g. making a preamp input impedance 200Ω to match a 200Ω microphone) still reduces the microphone output and signal to noise ratio by 6dB, which is undesirable.

To minimise microphone loading, and to maximise signal to noise ratio, preamps have traditionally been designed to have an input impedance about ten times greater than the average microphone, around 1.2kΩ to 2kΩ. (The original ISA 110 pre-amp design followed this convention and has an input impedance of 1.4kΩ at 1kHz.) Input impedance settings greater than 2kΩ tend to make the frequency-related variations of microphone outputs less significant than at low impedance settings. Therefore high input impedance settings yield a microphone performance that is flatter in the low and mid frequency areas and boosted in the high frequency area when compared to low impedance settings.

Ribbon microphones

The impedance of a ribbon microphone is worthy of special mention, as this type of microphone is affected enormously by preamp impedance. The ribbon impedance within this type of microphone is incredibly low, around 0.2Ω, and requires an output transformer to convert the extremely low voltage it can generate into a signal capable of being amplified by a pre-amp. The ribbon microphone output transformer requires a ratio of around 1:30 (primary: secondary) to increase the ribbon voltage to a useful level, and this transformer ratio also has the effect of increasing the output impedance of the mic to around 200Ω at 1kHz. This transformer impedance, however, is very dependent upon frequency - it can almost double at some frequencies (known as the resonance point) and tends to roll off to very small values at low and high frequencies.

Therefore, as with the dynamic and condenser microphones, the mic preamp input impedance has a massive effect on the signal levels and frequency response of the ribbon microphone output transformer, and thus the 'sound quality' of the microphone. It is recommended that a mic pre-amp connected to a ribbon microphone should have an input impedance of at least 5 times the nominal microphone impedance.

For a ribbon microphone impedance of 30Ω to 120Ω, the input impedance of 600Ω(Low) will work fine. For 120Ω to 200Ω ribbon microphones, the input impedance setting of 1.4kΩ(ISA 110) is recommended.

Impedance Setting Quick Guide

In general, the following selections will yield these results:

High mic pre-amp impedance settings

- will generate more overall level
- will tend to make the low- and mid-frequency response of the microphone flatter
- will improve the high-frequency response of the microphone.

Low pre-amp impedance settings

- will reduce the microphone output level
- will tend to emphasise the low- and mid-frequency presence peaks and resonant points of the microphone

Signal Connections

Recording an analogue vocal signal through a desk with backing tracks

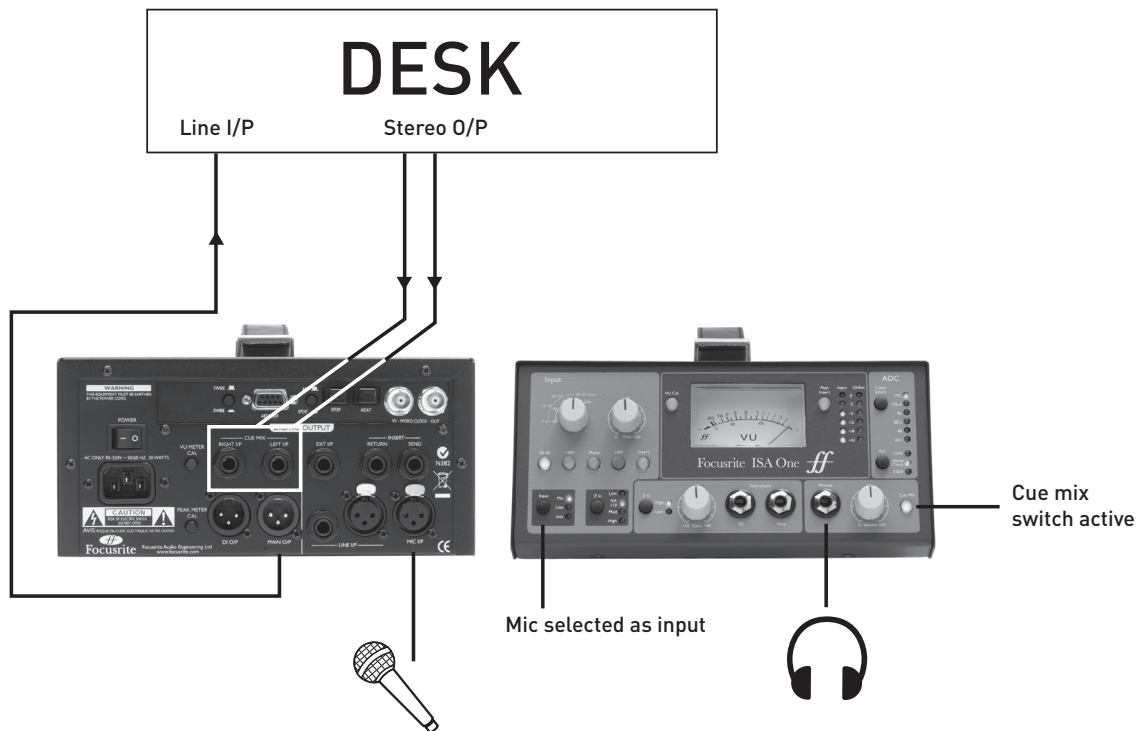

In this low-latency environment, the vocal can be sent to the desk, mixed with the backing tracks and then a stereo mix be sent back to the ISA One, via the cue mix inputs.

Recording an analogue guitar signal directly to the DAW with backing tracks

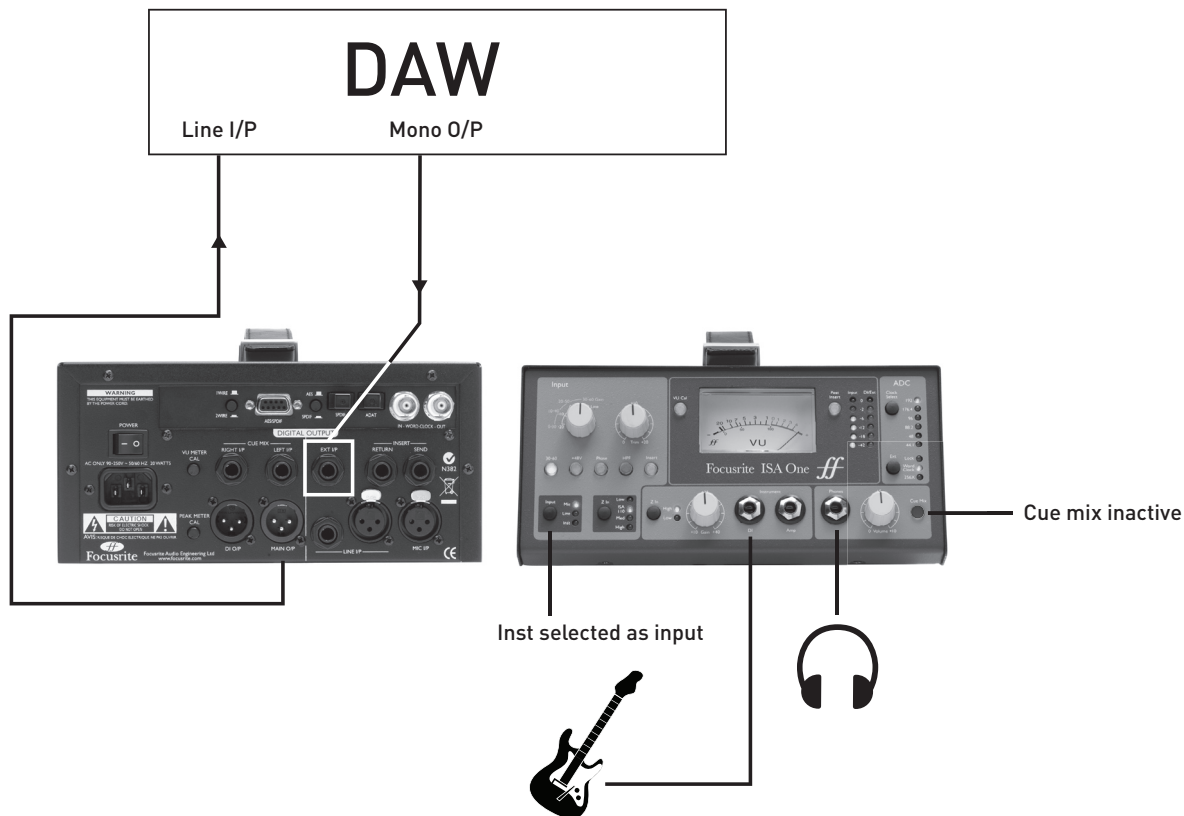

With the cue mix switch inactive, the mix in the headphones is a fixed blend of both inputs. The inputs in this case are the guitar (INST) signal and the mono (EXT IP) signal from the DAW. This provides a latency-free mix of the guitar and backing tracks in the headphones.

Recording an analogue guitar signal using both inputs

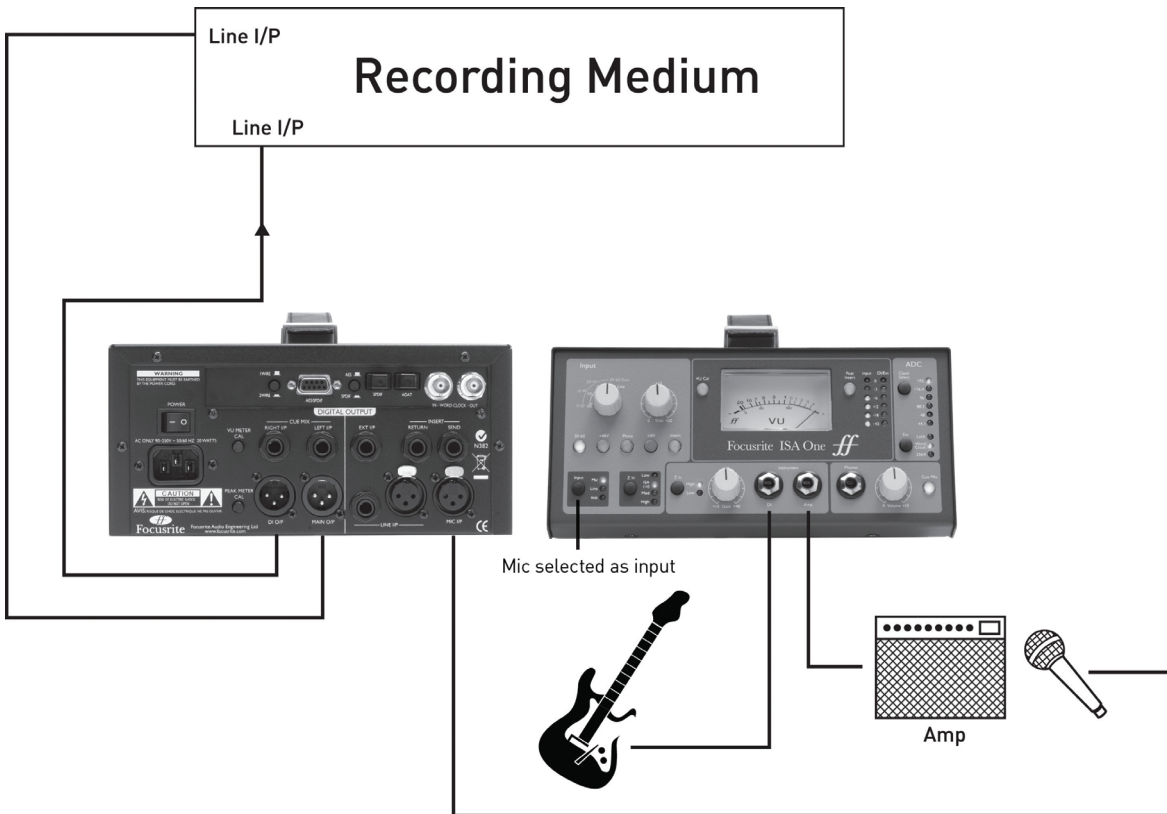

In this instance, should you want to record the signals digitally, the stereo output of the optional digital card (if installed) will mirror the MAIN and DI outputs (left and right respectively).

If recording through a desk or other low-latency environment, a stereo mix with backing tracks and guitar can be sent back to ISA One's CUE MIX inputs to allow a latency-free headphones mix for the guitarist (as in diagram 1).

If recording to a DAW, a mono backing tracks mix can be sent to ISA One, via the EXT IP (as in diagram 2). However, this will make the second channel of the digital card's stereo output become the EXT IP signal and not the DI IP, meaning the mic'd and direct guitar signals must be recorded using the analogue connections shown above.

Specifications

Mic Input Response

- Gain range = 0dB to 60dB in 10dB steps + 20 dB of variable gain
- Input Impedance, variable as follows:-

Switched Impedance setting Equivalent Input Impedance at 1kHz

Low = 600Ω

ISA110 = 1400Ω

Med = 2400Ω

High = 6800Ω

- EIN (equivalent input noise) = -126dB measured at 60dB of gain with 150Ω terminating impedance and 22Hz/22kHz band-pass filter
- Noise at main output with gain at unity (0dB) = -97dBu measured with a 22Hz/22kHz band-pass filter
- Signal to noise ratio relative to max headroom (9dBu) = 106dB
- THD at medium gain (30dB) = 0.0009% measured with a 1kHz -20dBu input signal and with a 22Hz/22kHz band-pass filter
- Frequency response at minimum gain (0dB) = -0.5dB down at 10Hz and -3dB down at 125kHz

- Frequency response at maximum gain (60dB) = -3dB down at 16Hz and -3dB down 118kHz
- CMRR=98dB (Channel 1, 1kHz, maximum gain with +24 dBu input)
- Crosstalk Channel to Channel: with 10dB@1kHz input to chA, chB output =104dBrA. With 10dB@10kHz input to chA, chB output = 84dBrA

Line Input Response

- Gain range = -20dB to +10dB in 10dB steps + 20 dB of variable gain
- Input Impedance = 10kΩ from 10Hz to 200kHz
- Noise at main output with gain at unity (0dB) = -96dBu measured with a 22Hz/22kHz band-pass filter
- Signal to noise ratio relative to max headroom (24dBu)=120dB
- Signal to noise ratio relative to 0dBFS (+22dBu) = 118dB
- THD at unity gain (0dB) = 0.001% measured with a 0dBu input signal and with a 22Hz/22kHz band-pass filter
- Frequency Response at unity gain (0dB) = -0.3dB down at 10Hz and -3dB down at 200kHz

Instrument Input Response

- Gain range = 10dB to 40dB continuously variable
- Input Impedance:
 - High = 1MΩ
 - Low = 300kΩ
- Noise at minimum gain (+10dB) = -92dBu measured with a 22Hz/22kHz band-pass filter
- Noise at maximum gain (+40dB) = -62dBu measured with a 22Hz/22kHz band-pass filter
- THD at minimum gain (+10dB) = 0.001% measured with a 10dBu input signal and with a 22Hz/22kHz band-pass filter
- Frequency Response at 10dB gain with -10dB input = 10Hz-100kHz +/- 0.6dB
- Frequency Response at 40dB gain with -40dB input = -2.5dB down at 10Hz and 0dB at 100kHz

High Pass Filter

- Roll off = 18dB per octave 3 pole filter
- Fixed Frequency 75Hz measured at the 3dB down point

Meters

- Moving coil (MC) meter is factory calibrated to 0VU = +4dBu with 1kHz sinewave. With the VU Cal button pressed, the meter can be adjusted on the rear panel to allow 0VU to equal +10dBu to +26dBu with the centre detent being equal to +22dBu
- Peak LED meters calibrated in the detent position for 0dBFS = +22dBu, calibration is adjustable on the rear panel to allow 0dBFS to equal +10dBu to +26dBu

Routing for MC and Peak1 meter is after the HPF, pre insert send or switched post insert return. Peak2 is always pre ADC channel 2, which can be fed by external input or Instrument input.

LED levels are as follows when peak calibration is set to center detent on the rear panel. (This is when using the internal ADC).

- 0 = +22dBu
- 2 = +20dBu
- 6 = +16dBu
- 12 = +10dBu
- 18 = +4dBu
- 42 = -20dBu

Front and Rear Connectivity

Analogue Channel Inputs:

Mic input: XLR x 1

Line input: XLR x 1 and TRS x 1

Instrument input TS Jack x 1

External ADC input: TRS Jack x 1

Return: TRS Jack x 1

Analogue Channel Outputs:

Send: TRS Jack x 1

Balanced line output: XLR x 1

DI output: XLR x 1

DI through: TS Jack x 1

Analogue Channel Additional I/O:

Cue mix left input: TRS Jack x 1

Cue mix right input: TRS Jack x 1

Headphones output: ¼" TRS Jack x 1

Warranty

All Focusrite products are covered by a warranty against manufacturing defects in material or craftsmanship for a period of one year from the date of purchase. Focusrite in the UK, or its authorised distributors worldwide, will do their best to ensure that any fault is remedied as quickly as possible. This warranty is in addition to your statutory rights.

This warranty does not cover any of the following:

- Carriage to and from the dealer or factory for inspection or repair
- Labour charge if repaired other than by the distributor in the country of purchase or Focusrite in the UK
- Consequential loss or damage, direct or indirect, of any kind, however caused
- Any damage or faults caused by abuse, negligence, improper operation, storage or maintenance

If a product is faulty, please first contact the dealer from which the product was purchased. If the product is to be shipped back, please ensure that it is packed correctly, preferably in the original packing materials. We will do our best to remedy the fault as quickly as possible.

Please help us to serve you better by completing and returning the Warranty Registration Card, or registering online at <http://www.focusrite.com>. Thank you.

Accuracy

Whilst every effort has been made to ensure the accuracy and content of this manual, Focusrite Audio Engineering Ltd makes no representations or warranties regarding the contents.

Copyright

© 2007-2008 Focusrite Audio Engineering Ltd. All rights reserved. No part of this manual may be reproduced, photocopied, stored on a retrieval system, transmitted or passed to a third party by any means or in any form without the express prior consent of Focusrite Audio Engineering Ltd. ADAT™ is a registered trade mark of Alesis Corporation Inc. E & O.E.