

LED DMX-CONTROL XLR MK2



ENGLISH Operation Manual

Other languages can be downloaded from:
WWW.JB-SYSTEMS.EU



Version: 1.0

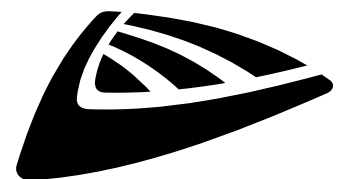

JB SYSTEMS



EN - DISPOSAL OF THE DEVICE

Dispose of the unit and used batteries in an environment friendly manner according to your country regulations.

FR - DÉCLASSER L'APPAREIL

Débarrassez-vous de l'appareil et des piles usagées de manière écologique conformément aux dispositions légales de votre pays.

NL - VERWIJDEREN VAN HET APPARAAT

Verwijder het toestel en de gebruikte batterijen op een milieuvriendelijke manier conform de in uw land geldende voorschriften.

DU - ENTSORGUNG DES GERÄTS

Entsorgen Sie das Gerät und die Batterien auf umweltfreundliche Art und Weise gemäß den Vorschriften Ihres Landes.

ES - DESHACERSE DEL APARATO

Reciclar el aparato y pilas usadas de forma ecologica conforme a las disposiciones legales de su país.

PT - COMO DESFAZER-SE DA UNIDADE

Tente reciclar a unidade e as pilhas usadas respeitando o ambiente e em conformidade com as normas vigentes no seu país.

OPERATION MANUAL

Thank you for buying this JB Systems® product. To take full advantage of all possibilities, please read these operating instructions very carefully.

FEATURES

- Extremely versatile DMX LED-controller for all kinds of passive 12V_{dc} / 24V_{dc} LED-projectors like led strips.
- Can be used for both RGB and 1color led strips.
- PWM technology for smooth and flicker-free dimming from 0% to 100%
- Easy electrical installation: equipped with XLR and RJ45 DMX-in/out + wire terminal LED-outputs
- Max output: 40W/ch = 120W @ 12V_{dc} or 80W/ch = 240W @ 24V_{dc}
- LED-output power can always be increased using our [LED REPEATER] boosters.
- All functions can be controlled:
 - Directly on the on the controller (DIP switches)
 - Using an optional LEDCON-02 Mk2 (also with sound mode)
 - Using any standard DMX-controller
- Different standalone working modes:
 - Fixed color mode: Instant access to 7 pre-programmed colors
 - Auto chase mode: 7 color chase with 7 different speeds.
 - Fade chase mode: 7 colors fading smoothly at 7 different speeds.
- 4 DMX channels needed: Ch1=red, Ch2=green, Ch3=Blue, Ch4=Dimmer/strobe.
- Enclosure prepared for easy installing against the wall.
- Perfect for use in LED installations for homes, shops, ...
- No fan cooling: completely silent!

BEFORE USE

Check the contents:

Check that the carton contains the following items:

- LED DMX-CONTROL XLR Mk2 unit
- User manual

Some important instructions:

- Before you start using this unit, please check if there's no transportation damage. Should there be any, do not use the device and consult your dealer first.
- **Important:** This device left our factory in perfect condition and well packaged. It is absolutely necessary for the user to strictly follow the safety instructions and warnings in this user manual. Any damage caused by mishandling is not subject to warranty. The dealer will not accept responsibility for any resulting defects or problems caused by disregarding this user manual.
- Keep this booklet in a safe place for future consultation. If you sell the fixture, be sure to add this user manual.
- To protect the environment, please try to recycle the packing material as much as possible.

SAFETY INSTRUCTIONS:



This symbol means: indoor use only



This symbol means: Read instructions



This symbol means: Lamp Control Gear



The device is suitable for mounting on standard flammable surfaces. Standard flammable surfaces include building materials such as wood and wood-based materials more than 2mm thick.

- To prevent fire or shock hazard, do not expose this appliance to rain or moisture.
- To avoid condensation to be formed inside, allow the unit to adapt to the surrounding temperatures when bringing it into a warm room after transport. Condense sometimes prevents the unit from working at full performance or may even cause damages.
- This unit is for indoor use only.
- Don't place metal objects or spill liquid inside the unit. No objects filled with liquids, such as vases, shall be placed on this appliance. Electric shock or malfunction may result. If a foreign object enters the unit, immediately disconnect the mains power.
- No naked flame sources, such as lighted candles, should be placed on the appliance.
- Don't cover any ventilation openings as this may result in overheating.
- Prevent use in dusty environments and clean the unit regularly.
- Keep the unit away from children.
- Inexperienced persons should not operate this device.
- Maximum safe ambient temperature is 40°C. Don't use this unit at higher ambient temperatures.
- Always unplug the unit when it is not used for a longer time or before you start servicing.
- The electrical installation should be carried out by qualified personal only, according to the regulations for electrical and mechanical safety in your country.
- Check that the available voltage is not higher than the one stated on the rear panel of the unit.
- Please use the original packing when the device is to be transported.
- Due to safety reasons it is prohibited to make unauthorized modifications to the unit.

MAINTENANCE

Clean by wiping with a polished cloth slightly dipped with water. Avoid getting water inside the unit. Do not use volatile liquids such as benzene or thinner which will damage the unit.

FUNCTIONS

- DMX INPUT:** use the 3pin male XLR-connector to connect universal DMX-cables or the RJ45-connector to connect with regular CAT5 cables. This input receives instructions from a DMX-controller.
- DMX OUTPUT:** 3pin female XLR-connector or RJ45-connector used to connect the unit with the next DMX appliance in the chain.
- OUTPUT TERMINALS:** used to connect different 24Vdc (or 12Vdc) common anode LED projectors. Make sure you don't exceed the max. allowed power.
- POWER INPUT:** connect the power supply (12Vdc or 24Vdc) here. (check the polarity !)
- DIP SWITCHES:** used to set the LED DMX-CONTROL in the desired working mode.

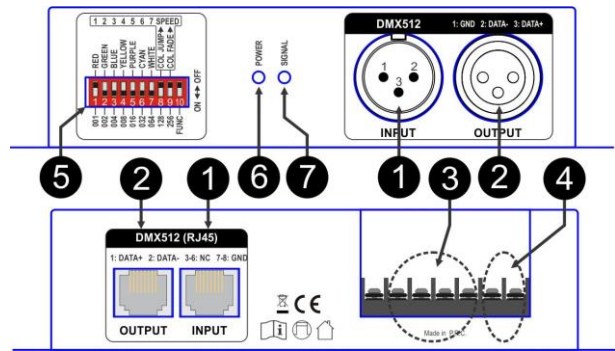

DMX-mode:

- Set DIP-switch10 [DIP10] to [OFF] position (switch up)
- Set the DMX-starting address according to the table:
The first 9 DIP-switches correspond to a certain DMX-value:

[DIP-SW]	1	2	3	4	5	6	7	8	9	10
Value	1	2	4	8	16	32	64	128	256	[OFF]

Each controller needs 4 DMX-addresses. You can combine the values of these switches to obtain any starting address between 1 and 512:

- Begin address = 01 → switch 1=ON values: 1
- Begin address = 05 → switch 1+3=ON values: 1+4 = 5
- Begin address = 09 → switch 1+4=ON values: 1+8 = 9
- Begin address = 13 → switch 1+3+4=ON values: 1+4+8 = 13
- ...
- Begin address = 62 → switch 2+3+4+5+6=ON values: 2+4+8+16+32 = 62

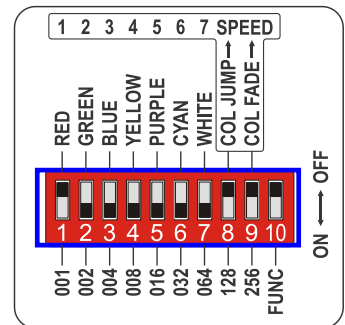

4CH DMX CHART:

VALUE	CH1 RED	CH2 GREEN	CH3 BLUE	VALUE	CH4 DIM/STROBE
255	100%	100%	100%	248-255	100%
				247	STROBE FAST
				201	STROBE SLOW
				191-200	DIM 100%
				190	DIM 100%
				008	DIM 0%
000	0%	0%	0%	000-007	OFF

Standalone-modes:

- Set DIP-switch10 [DIP10] to [ON] position (switch down)
- **Static colors:** set the DIP-switches according to the table:

[DIP-SW]	1	2	3	4	5	6	7	8	9	10
Color	red	green	blue	yellow	purple	cyan	white	[OFF]	[OFF]	[ON]

- **JUMPING colors:** set the DIP-switches according to the table for the desired speed:

[DIP-SW]	1	2	3	4	5	6	7	8	9	10
Speed	1	2	3	4	5	6	7	[ON]	[OFF]	[ON]

- **FADING colors:** set the DIP-switches according to the table for the desired speed:

[DIP-SW]	1	2	3	4	5	6	7	8	9	10
Speed	1	2	3	4	5	6	7	[ON]	[OFF]	[ON]

- POWER ON LED:** used to check if the unit receives power.
- STATUS LED:** shows the status of the unit, should blink when DMX is detected.

ELECTRICAL INSTALLATION

SIMPLE STANDALONE

With the DIP-switches (see previous chapter for DIP-switch settings) you can select one of the 7 static colors or color jumps/fades with 7 different speeds.

Follow these instructions:

- Calculate the total power of the led strip. The power of led strips is mostly given in watt/meter (W/m).
Example: the power of your ledstrip = 9,6W/m and length = 5m
*The total power = 9,6 W/m * 5m = 48W*
- Choose an adapted power supply based on the previous calculation. For long-term reliability we suggest to add about 20% power reserve and choose the nearest power supply exceeding this calculation.
Example: in our example we need 48W. So we add 20%: 48W + 20% = ±58W
The nearest power supply in this case is our 60W / 24V power supply.
- Connect the power supply output to the Power input of the unit. (don't mix-up the polarity of the wires!)
- Connect the led strip to the output of the unit: Red wire to [R], green wire to [G], blue wire to [B] and the 4th wire to the [V+]. (don't mix-up the polarity of the wires!)
- *Remark: don't connect more than 5m led strip in series, excessive current will damage the led strip. Instead you can connect the led strips in parallel.*
- Switch on the power supply AFTER you checked all connections.
- Switch 10 of the DIP-switch must be in the [ON] position: now set the other switches in the desired position (see previous chapter).

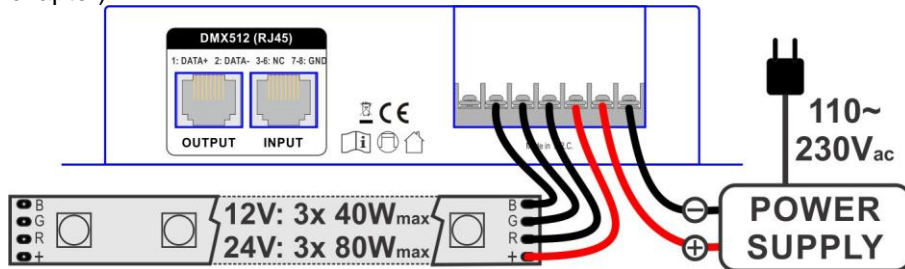

DMX-OPERATION: basic setup for a regular RGB-installation

Two parts are involved:

- Connections for DMX-input (see below schematic) and DIP-switch configuration (see previous chapter)
- Connections for LED-outputs (same as for standalone operation)

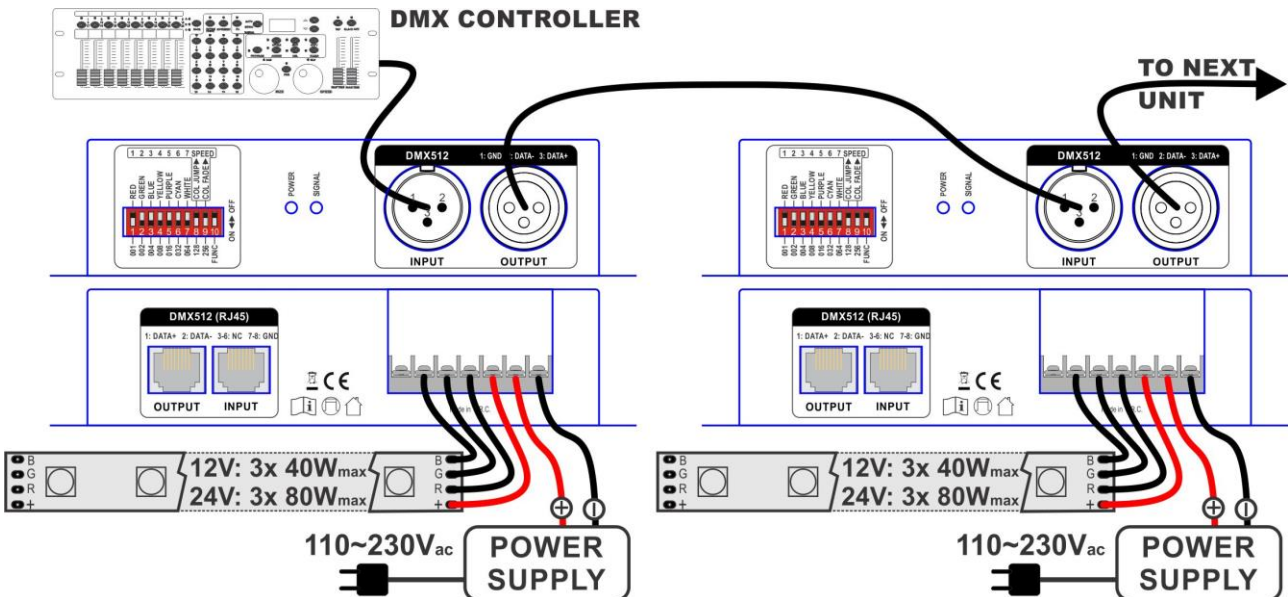

DMX-OPERATION: basic setup for use with 1COLOR LED STRIPS

Basically this is the same setup as for RGB led strips, the only difference is that you only have 1 color instead of 3. This means that 3 LED strip lines can be dimmed independently (each led strip is connected to a different channel). Refer to the schematic:

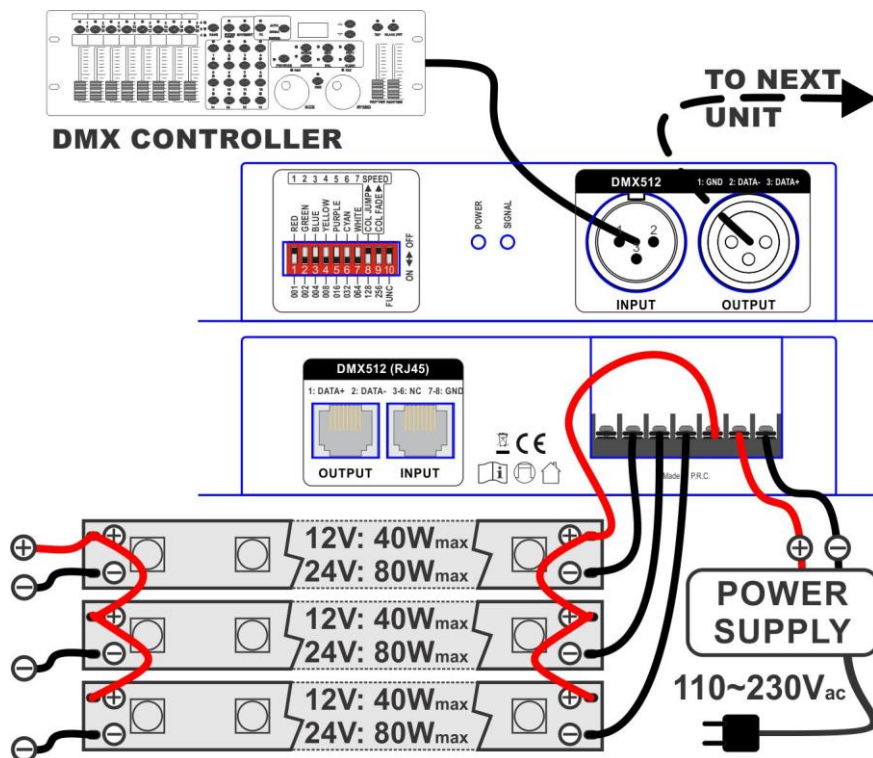

SOME GENERAL GUIDELINES

You can make any desired installation BUT you have to keep some important guidelines in mind:

- Calculate the total power of the led strips and add $\pm 20\%$ to determine the power of the power supplies.
- Never connect led strips together in lengths exceeding 5m, instead:
 - Connect the strips in parallel:

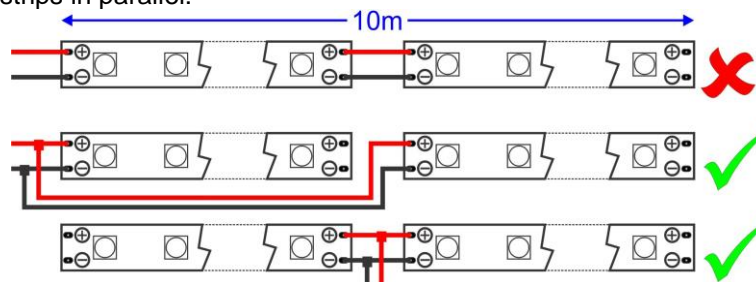

- Use one or more [LED-REPEATER] + extra power supplies to extend the led strips.
- Use wires with a maximum cable section to reduce important voltage drops. Use at least 1,5mm² wires, for higher power and cable lengths we suggest 2,5mm². Even better is to calculate the voltage drop and use special charts to determine the perfect cable section.

SPECIFICATIONS

This unit is radio-interference suppressed. This product meets the requirements of the current European and national guidelines. Conformity has been established and the relevant statements and documents have been deposited by the manufacturer.

Power Input:	12Vdc or 24Vdc (depends on the voltage of the led strips)
DMX connections:	XLR 3pin + RJ45 (DMX-512 standard, 4 channels) CH1: Red, CH2: Green, CH3: Blue, CH4: Dim/Strobe
Max output:	3ch common anode 40Watt/channel (total = 120W) @12V 80Watt/channel (total = 240W) @ 24V
Dimensions (LxWxH):	165 x 66 x 42 mm
Weight:	310 g

Every information is subject to change without prior notice

You can download the latest version of this user manual on our website: www.jb-systems.eu



JB SYSTEMS

MAILING LIST

EN: Subscribe today to our mailing list for the latest product news!

FR: Inscrivez-vous à notre liste de distribution si vous souhaitez suivre l'actualité de nos produits!

NL: Abonneer je vandaag nog op onze mailinglijst en ontvang ons laatste product nieuws!

DE: Abonnieren Sie unseren Newsletter und erhalten Sie aktuelle Produktinformationen!

ES: Suscríbete hoy a nuestra lista de correo para recibir las últimas noticias!

PT: Inscreva-se hoje na nossa mailing list para estar a par das últimas notícias!

WWW.JB-SYSTEMS.EU

Copyright © 2018 by BEGLEC NV

t Hofveld 2C ~ B1702 Groot-Bijgaarden ~ Belgium

Reproduction or publication of the content in any manner, without express permission of the publisher, is prohibited.