

**KURZWEIL®**

# **KA-130**

## USER'S MANUAL

English Manual

**HDC** YOUNG CHANG  
MUSIC



# Precaution

Thank you for purchasing this digital instrument. For perfect operation and security, please read the manual carefully and keep it for future reference.

## Safety Precautions



The lightning flash with arrowhead symbol within an equilateral triangle is intended to alert the user to the presence of uninsulated "dangerous voltage" within the product's enclosure that may be of sufficient magnitude to constitute a risk of electric shock to persons.



The exclamation point within an equilateral triangle is intended to alert the user to the presence of important operating and maintenance(servicing) instructions in the literature accompanying the product.

## Important Safety Instructions



(Figure 1)

- 1) Read these instructions.
- 2) Keep these instructions.
- 3) Heed all warnings.
- 4) Follow all instructions.
- 5) Do not use this apparatus near water.
- 6) Clean only with dry cloth.
- 7) Do not block any ventilation openings, install in accordance with the manufacturer's instructions.
- 8) Do not install near any heat sources such as radiators, heat registers, stoves, or other apparatus (including amplifiers) that produce heat.
- 9) Do not defeat the safety purpose of the polarized or grounding-type plug. A polarized plug has two blades with one wider than the other. A grounding type plug has two blades and a third grounding prong. The wide blade or the third prong are provided for your safety, if the provided plug does not fit into your outlet, consult an electrician for replacement of the obsolete outlet.
- 10) Protect the power cord from being walked on or pinched particularly at plugs, convenience receptacles, and the point where they exit from the apparatus.
- 11) Only use attachments/accessories specified by the manufacturer.
- 12) Use only with the cart, stand, tripod, bracket, or table specified by the manufacturer, or sold with the apparatus. When a cart is used, use caution when moving the cart/apparatus combination to avoid injury from tip-over (Figure 1).
- 13) Unplug this apparatus during lightning storms or when unused for a long periods fo time.
- 14) Refer all servicing to qualified service personnel. Servicing is required when the apparatus has been damaged in any way, such as power-supply cord or plug is damaged, liquid has been spilled or objects have fallen into the apparatus, the apparatus has been exposed to rain or moisture, does not operate normally, or has been dropped.

**WARNING:** To reduce the risk of fire or electric shock, do not expose this apparatus to rain or moisture.

**CAUTION:** Apparatus shall not be exposed to dripping or splashing and no objects filled with liquids, such as vases, shall be placed on the apparatus.

# **Thanks For Using Our Digital Piano**

Your piano is a high-quality digital piano with 88 standard size touch sensitivity keyboard and combines the most advanced PCM tone generation technology. The LED digital display brings great convenience to your operation. To satisfy your diversified demand, your instrument has multi-track recording, memory half-pedal and USB Audio functions and can let you enjoy a perfect digitized sound stage effect.

In order to obtain maximum performance and enjoyment, please read this manual thoroughly while trying out the various features described.

# Contents

<b>Panel Contents</b> .....	3
<b>Connectors</b> .....	4
DC Power .....	4
Headphones .....	4
Foot Pedals .....	4
Line In/Out .....	6
USB-MIDI/USB AUDIO .....	6
<b>Basic Operation</b> .....	7
Power Switch .....	7
Master Volume .....	7
Demo/Learning Songs .....	7
<b>Voices</b> .....	8
Selecting a Voice .....	8
Layer Mode .....	8
Metronome .....	9
Split Mode .....	9
DUO Piano Mode .....	10
Grand Piano .....	10
<b>Function</b> .....	11
<b>Song Recording</b> .....	29
Record .....	29
Playback .....	29
Delete .....	30
<b>Teaching Function</b> .....	31
Learning Mode .....	31
1.3-Step Learning .....	31
Automatic Scoring .....	32
Left/Right Part Learning .....	32
Exit the Learning Mode .....	32
<b>Factory Set</b> .....	33
<b>Appendix</b> .....	34
Normal Voice List (16) .....	34
GM Voice List (128) .....	35
Troubleshooting Hints .....	36
Specifications .....	37
Assembly Instruction .....	38

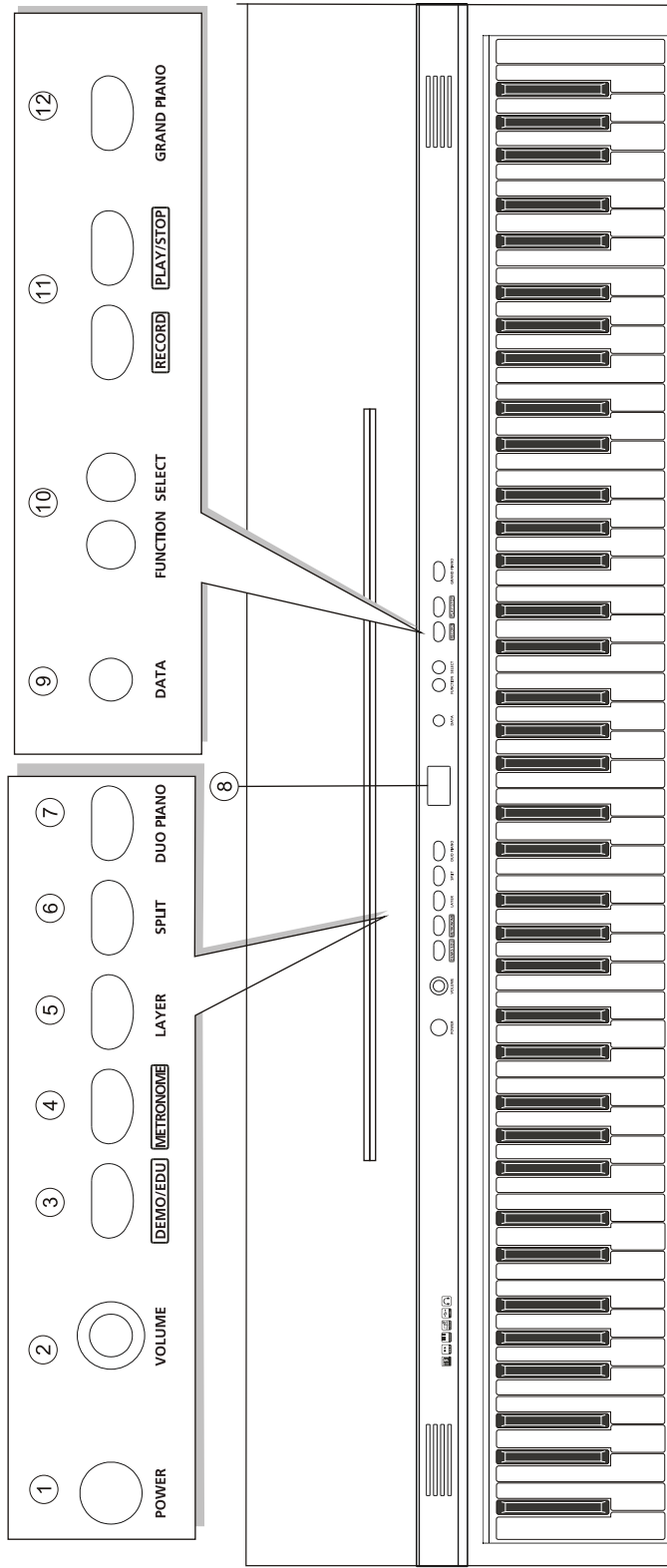
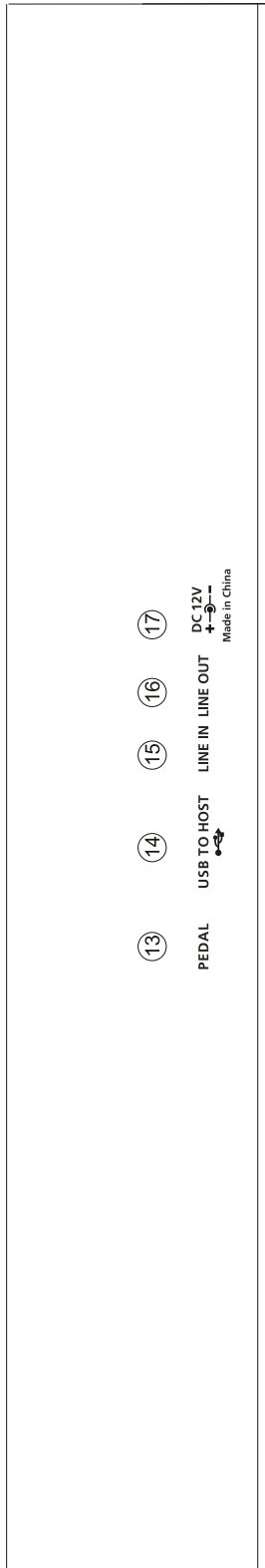

# Panel Contents

## Top Panel

- 1) [POWER] Button
- 2) VOLUME
- 3) [DEMO/EDU] Button
- 4) [METRONOME] Button
- 5) [LAYER] Button
- 6) [SPLIT] Button
- 7) [DUO PIANO] Button
- 8) MULTI DISPLAY
- 9) DATA CONTROL
- 10) [FUNCTION] Button  
    [SETECT] Button
- 11) [RECORD] Button  
    [PLAY/STOP] Button
- 12) [GRAND PIANO] Button

## Rear Panel

- 13) [PEDAL] Jack
- 14) [USB TO HOST] Jack
- 15) [LINE IN] Jack
- 16) [LINE OUT] Jack
- 17) [DC 12V] Jack
- 18) [PHONES1] Jack  
    [PHONES2] Jack

# Connectors

## DC Power

1. Ensure the keyboard is turned off when connecting and disconnecting the power, and turn the volume to the minimum level.
2. Plug the adaptor into the AC wall outlet and the cord into the unit, then turn the power on.

## Headphones

Two sets of standard stereo headphones can be plugged in here for private practice or late-night playing. The internal speaker system is automatically shut off when the headphone is plugged into PHONES jacks.

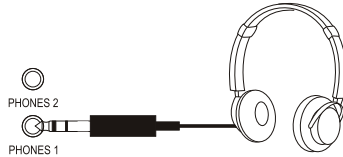

## Foot Pedals

Connect the plug of the foot pedal unit to the pedal jack on the rear panel.

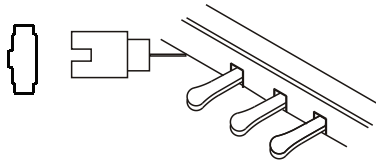



### **Damper Pedal (Right)**

It performs the same function as the damper pedal on an actual acoustic piano, letting you sustain the sound of the voices even after releasing your fingers from the keys.

Your piano has Half-pedal function. You may release your foot from the pedal on different positions to change the sustain time. The less you release your foot from the pedal, the longer the sustain effect lasts.

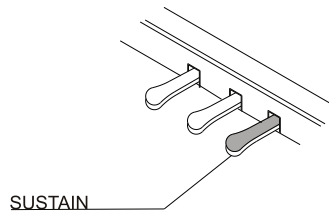

### **Sostenuto Pedal (Center)**

If you play a note or chord on the keyboard and press the sostenuto pedal while the notes are held, those notes will be sustained as long as the pedal is held, but all subsequently played notes will not be sustained.

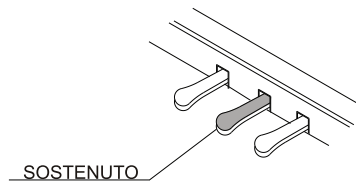

### **Soft Pedal (Left)**

The Soft Pedal controls the sound volume. Press the pedal to decrease the output sound volume.

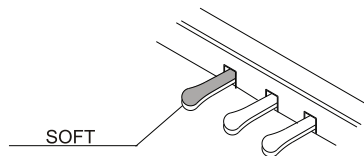

---

## Line In/Out

Connect the external sound system to the LINE IN jack. The audio signal from the external sound system can be mixed with the sound of your piano. This function is convenient when you want to play along with your favourite song.

The LINE OUT jack can be used to transmit the audio signal of the piano to a keyboard amplifier, stereo sound system, mixing console or tape recorder.

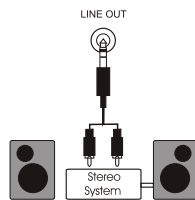

---

## USB-MIDI/USB AUDIO

This product allows the transfer of MIDI over USB. There is a specific way in which the MIDI signals are routed for maximum flexibility. In a standard Digital Piano, the built-in keyboard sends MIDI signals to the internal sound bank as well as the 5-pin MIDI output. In this digital piano, the keyboard not only sends MIDI signals to the internal sound bank (just like normal) but also sends MIDI signals simultaneously to the internal MIDI connection which hooks up inside the device to the Audio Interface. It is the Audio Interface to control the USB-MIDI.

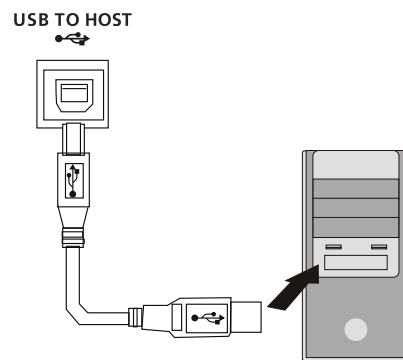

USB AUDIO interface is a digital audio interface. By USB cable, you can digitally transfer intact audio signals of PC to your piano, and enjoy it by your piano or use it to accompany your performance.

# Basic Operation

## Power Switch

Press the [STANDBY/ON] button to turn on the power and the LED will light.



### NOTE

*This product will switch off automatically in 30 minutes after no any operation on it. (See page 28 for details.)*

## Master Volume

Turn the [VOLUME] knob to adjust the volume to your desired level.



## Demo/Learning Songs

There are 50 demo songs and 221 learning songs(b01~b99~106, C01~C30, C01~C40, S01~S45). You may select your desired one to play individually.

### Listen to the Demo Song

Press the [DEMO/EDU] button to enter demo/learning songs function. Use the [DATA] knob to select the number of the song you want to play.

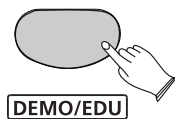

Demo Songs: d01~d50

Learning Songs: b01~b99~106, C01~C30, C01~C40, S01~S45.

### Stop Playing

Press the [DEMO/EDU] button again to stop playing.

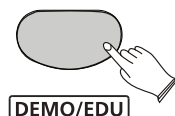

# Voices

## Selecting a Voice

Your instrument has 16 normal voices.  
Use the [DATA] knob to select the desired voice.

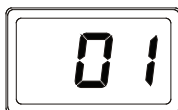

## LAYER Mode

Press the [LAYER] button to select LAYER Mode, and then two different voices will sound simultaneously when you play the keyboard.

### Select Layer Voice

Press the [LAYER] button and its indicator will flash. Use the [DATA] knob to select the second voice. If you don't choose the second voice within 4 seconds, the LED will return to display the Main voice.

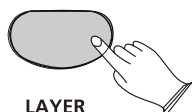

### Set Layer Voice Volume

**Reference:** Adjusting Keyboard Volume (P.19).

#### **NOTE**

*To change the Pan, Octave and Reverb/Chorus Depth of the Layer voice, please refer to the instructions in [FUNCTION] section.*

### Exit Layer Mode

Press the [LAYER] button again to exit Layer Mode and its indicator will be unlighted.

---

## Metronome

Metronome is a convenient feature for practice, and it can also provide a solid rhythmic guide when recording.

The metronome sound is alternately turned on and turned off by pressing [METRONOME] button.

Hold the [METRONOME] button to enter the page for selecting the time signature. Then use the [DATA CONTROL] knob to select your desired time signature.

Time signature: 2/2, 1/4, 2/4, 3/4, 4/4, 5/4, 6/4, 3/8, 6/8, 7/8, 9/8, 12/8. (Default: 4/4)



---

## Split Mode

In the split mode, your keyboard will be split into two sections which means different voices can be played with the left and right hands at the same time.

Press the [SPLIT] button to enter Split Mode and the indicator will flash. Then you can use the [DATA] knob to select the Split Voice. When the indicator is no blinking, you may set the Main Voice.



Press the [SPLIT] button again to exit Split mode and the indicator will be unlighted.

---

## **DUO Piano Mode**

Press the [DUO PIANO] button to enter DUO PIANO Mode and the indicator will light. In this mode, the keyboard will be separated into two sections with the same voice range.

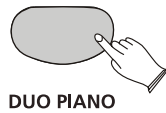

Right: from C#3 to C7  
Left: from A-1 to C3

---

## **Grand Piano**

Press the [GRAND PIANO] button. This convenient function lets you instantly call up the Grand Piano voice.



# Funtion

	FUN_NO	FUN_NAME	Range	Default(2)
<b>Performance</b>	F00	GM Mode	N-U: 16 Voice G-U: 128 Voice	N-u
	F01	Tempo	20~280	120
	F02	StaTranspose	-12~12	0
	F03	StaTune	-64~63	0
	F04	StamainOct	-2~2	0
	F05	StaSplitOct	-2~2	0
	F06	StaLayerOct	-2~2	0
	F07	StaMainPan	-64~63	0
	F08	StaSplitPan	-64~63	0
	F09	StaLayerPan	-64~63	0
	F10	StaSplitPoint	0~87	34
	F11	StaLocal	On/off	on
<b>MIXER</b>	F12	Stamainvol(*)	0~127	127
	F13	StaSplitVol(*)	0~127	127
	F14	StaLayerVol(*)	0~127	75
	F15	StaMetroVol(*)	0~127	100
	F16	StaSongVol(*)	0~127	100
<b>EFFECT</b>	F17	Stareverb(*)	00~08	05
	F18	StaRevvol(*)	0~127	15
	F19	StaChorus(*)	00~13	00
	F20	StaChoVol(*)	0~127	36
	F21	StaEQBass(*)	-12-12	0
	F22	StaEQTrebel(*)	-12-12	0
<b>Memory</b>	F23	StaMemBank	b01-b04	b01
	F24	StaMemLoad(1)	L01-L08	L01

	FUN_NO	FUN_NAME	Range	Default(2)
	F25	StaMemStore(1)	E01-E08	E01
<b>Learn</b>	F26	StaLessonTrack	L-r/L-L	L-r
	F27	Lesson Group	L-b/LC3/LC4/L-S	L-b
	F28	StaGrading	On/off	on
<b>Pedal Assign</b>	F29	StaPedal1	nor:normal p-1:Loadmemory	nor:sus
	F30	StaPedal2	nor:normal p-1:Loadmemory	nor:sos
	F31	StaPedal3	nor:normal p-1:Loadmemory	Nor:soft
<b>OtherFun</b>	F32	StaAutoCloseTime(*)	00, 20-60min	30min
	F33	FactoryReset(1)		
	F34	Touch	L-1/L-2/nor/ h-1/h-2/OFF	nor

(\*) indicates that the potentiometer can be stored when the power is off.

(1) indicates that after setting the value, press the [ENTER] button to confirm your setting during flashing, otherwise your setting will not be effective.

(2) indicates that in current status, press the [FUNCTION] and [ENTER] buttons at the same time to restore defaults.

## GM Mode

Press the [FUNCTION] button to enter the function mode and the LED will display "F00".



Press the [SELECT] button to confirm, and use the [DATA] knob to select n-U or G-U.

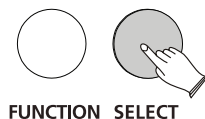

If you select n-U, hold the [GRAND PIANO] button, then press the keyboard from 1 key to 16 to select the 16 voices.



If you select G-U, hold the [GRAND PIANO] button, then press the keyboard from 1 key to 88 to select the 88 voices or use the [DATA CONTROL] knob to select 128 voices.

## Tempo

Press the [FUNCTION] button to enter the function mode and the LED will display "F01".



Press the [SELECT] button to confirm, and use the [DATA] knob to set Tempo value:20~280.

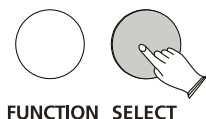

Press the [FUNCTION] and [SELECT] buttons simultaneously to restore the default value:120.

## Transpose

The Transpose function allows you to change the pitch of the instrument in semitone steps, up to a maximum setting of 12 semitones (a maximum of one octave up or down).

Press the [FUNCTION] button to enter the function mode, and use the [DATA] knob to select "F02".



Press the [SELECT] button to confirm, and use the [DATA] knob to set Transpose value:-12-12.

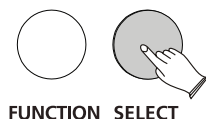

Press the [FUNCTION] and [SELECT] buttons simultaneously to restore the default Transpose value:0.

---

## Tune

The function makes it possible to tune the pitch of your instrument to match other instruments.

Press the [FUNCTION] button to enter the function mode, and use the [DATA] knob to select "F03".

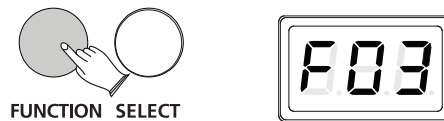

Press the [SELECT] button to confirm, and use the [DATA] knob to set the Tune value:-64-63.

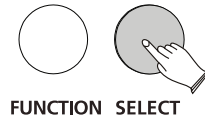

Press the [FUNCTION] and [SELECT] buttons simultaneously to restore the default Tune value:0.

---

## Main Voice Octave

In this function you can adjust the main voice octave value.

Press the [FUNCTION] button to enter the function mode, and use the [DATA] knob to select "F04".



Press the [SELECT] button to confirm, and use the [DATA] knob to set the main voice octave value: -2 to 2.

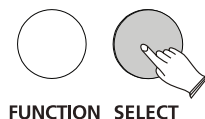

Press the [FUNCTION] and [SELECT] buttons simultaneously to restore the default value:0.

---

## Split Voice Octave

In this function you can adjust the split voice octave value.

Press the [FUNCTION] button to enter the function mode, and use the [DATA] knob to select "F05".

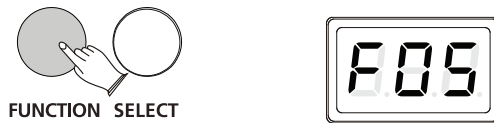

Press the [SELECT] button to confirmation, and the [DATA] knob to set the split voice octave value: -2 to 2.

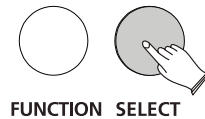

Press the [FUNCTION] and [SELECT] buttons simultaneously to restore the default value:0.

---

## Layer Voice Octave

In this function you can adjust the layer voice octave value.

Press the [FUNCTION] button to enter the function mode, and use the [DATA] knob to select "F06".



Press the [SELECT] button to confirm, and use the [DATA] knob to set the layer voice octave value: -2 to 2.

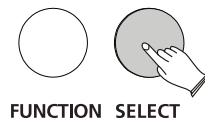

Press the [FUNCTION] and [SELECT] buttons simultaneously to restore the default value:0.

## Main Voice Pan

In this function you can set the stereo position of each orchestration part to create a board stereo image of your sound.

Press the [FUNCTION] button to enter the function mode, and use the [DATA] knob to select "F07".



Press the [SELECT] button to confirm, and use the [DATA] knob to set the main voice pan value: -64 to 63.

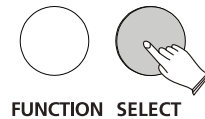

Press the [FUNCTION] and [SELECT] buttons simultaneously to restore the default value: 0.

## Split Voice Pan

Press the [FUNCTION] button to enter the function mode, and use the [DATA] knob to select "F08".



Press the [SELECT] button to confirm, and use the [DATA] knob to set the split voice pan value: -64 to 63.

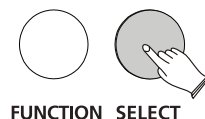

Press the [FUNCTION] and [SELECT] buttons simultaneously to restore the default value:0.

---

## Dual Voice Pan

Press the [FUNCTION] button to enter the function mode, and use the [DATA] knob to select "F09".



Press the [SELECT] button to confirm, and use the [DATA] knob to set the dual voice pan value: -64 to 63.

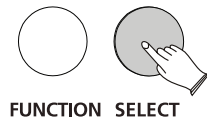

Press the [FUNCTION] and [SELECT] buttons simultaneously to restore the default value:0.

---

## Split Point

This function allows you to set the Split point for the Split mode.

Press the [FUNCTION] button to enter the function mode, and use the [DATA] knob to select "F10".



Press the [SELECT] button to confirm, and use the [DATA] knob to set the split point: 0 to 87.

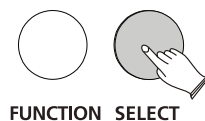

Press the [FUNCTION] and [SELECT] buttons simultaneously to restore the default split point: 34.

## Local Control

This function allows you to turn on or off the speaker system in your instrument.

Press the [FUNCTION] button to enter the function mode, and use the [DATA] knob to select "F11".



Press the [SELECT] button to confirm, and use the [DATA] knob to set On/Off.



Press the [FUNCTION] and [ENTER] buttons simultaneously to restore the default setting: On.

Local on----- Normal operation.

Local off----- Sound from speaker system, Line Out and headphone will be cut off.MIDI function may work as usual.

## Main Volume

Press the [FUNCTION] button to enter the function mode, and use the [DATA] knob to select "F12".



Press the [SELECT] button to confirm, and use the [DATA] knob to adjust the main volume range:0~127.

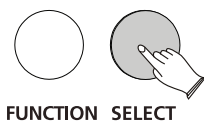

Press the [FUNCTION] and [SELECT] buttons simultaneously to restore the default setting:127.

## Split Volume

Press the [FUNCTION] button to enter the function mode, and use the [DATA] knob to select "F13".



Press the [SELECT] button to confirm, and use the [DATA] knob to adjust the split volume range:0~127.

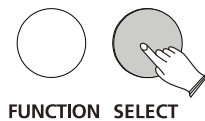

Press the [FUNCTION] and [SELECT] buttons simultaneously to restore the default setting:127.

## Layer Volume

Press the [FUNCTION] button to enter the function mode, and use the [DATA] knob to select "F14".



Press the [SELECT] button to confirmation, and use the [DATA] knob to adjust the layer volume range:0~127.

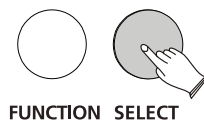

Press the [FUNCTION] and [SELECT] buttons simultaneously to restore the default setting:75.

## Metro. Volume

Press the [FUNCTION] button to enter the function mode, and use the [DATA] knob to select "F15".



Press the [SELECT] button to confirm, and use the [DATA] knob to adjust the Metronome volume range:0~127.

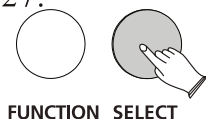

Press the [FUNCTION] and [SELECT] buttons simultaneously to restore the default setting:100.

## Learning song Volume

Press the [FUNCTION] button to enter the function mode, and use the [DATA] knob to select "F16".



Press the [SELECT] button to confirm, and use the [DATA] knob to adjust the learning song volume range:0~127.

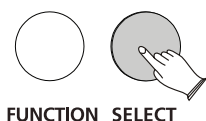

Press the [FUNCTION] and [SELECT] buttons simultaneously to restore the default setting:100.



## Reverb Type

Press the [FUNCTION] button to enter the function mode, and use the [DATA] knob to select "F17".



Press the [SELECT] button to confirm, and use the [DATA] knob to set the reverb type: 0:off, 1:Room1, 2:Room2, 3:Room3, 4:Hall 1, 5:Hall 2, 6:Plate, 7:Delay, 8:Echo.

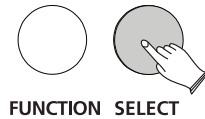

Press the [FUNCTION] and [SELECT] buttons simultaneously to restore the default setting:5:Hall 2.

## Reverb Level

Press the [FUNCTION] button to enter the function mode, and use the [DATA] knob to select "F18".



Press the [SELECT] button to confirm, and use the [DATA] knob to adjust the reverb level. Range: 00-127

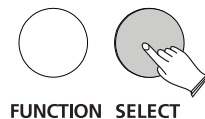

Press the [FUNCTION] and [SELECT] buttons simultaneously to restore the default setting:15.

## Chorus Type

Press the [FUNCTION] button to enter the function mode, and use the [DATA] knob to select "F19".



Press the [SELECT] button to confirm, and use the [DATA] knob to set the chorus type: 0:off, 1:Chorus 1, 2:Chorus 2, 3:Chorus 3, 4:Chorus 4, 5:Chorus Feedback, 6:Flanger1 Short Delay, 7:Short Delay Feedback, 8:Flanger 2, 9:Flanger 3, 10:Celeste 1, 11:Celeste 2, 12:Celeste 3, 13:Celeste 4.

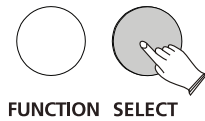

Press the [FUNCTION] and [SELECT] buttons simultaneously to restore the default setting: 0:off.

## Chorus Level

Press the [FUNCTION] button to enter the function mode, and use the [DATA] knob to select "F20".



Press the [SELECT] button to confirm, and use the [DATA] knob to adjust the chorus level. Range: 00-127

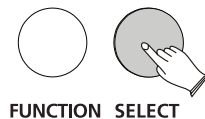

Press the [FUNCTION] and [SELECT] buttons simultaneously to restore the default setting: 36.

## EQ Bass

This function allows you to set the EQ Bass for the voice.

Press the [FUNCTION] button to enter the function mode, and use the [DATA] knob to select "F21".



Press the [SELECT] button to confirm, and use the [DATA] knob to adjust the value: -12~12.

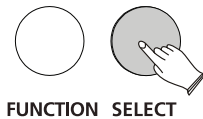

Press the [FUNCTION] and [SELECT] buttons simultaneously to restore the default setting:0.

## EQ Treble

This function allows you to set the EQ Treble for the voice.

Press the [FUNCTION] button to enter the function mode, and use the [DATA] knob to select "F22".



Press the [SELECT] button to confirm, and use the [DATA] knob to adjust the value: -12~12.



Press the [FUNCTION] and [SELECT] buttons simultaneously to restore the default setting:0.

## Registration Memory Bank

This function allows you to load all the setting data by one button. Your instrument has 8 Registration Memory sets with 4 banks.

Press the [FUNCTION] button to enter the function mode, and use the [DATA] knob to select "F23".



Press the [SELECT] button to confirm, and use the [DATA] knob to set the bank: b01~b04.

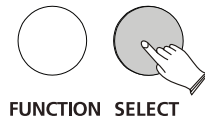

Press the [FUNCTION] and [SELECT] buttons simultaneously to restore the default Setting:b01.

## Loading Memory Data

Press the [FUNCTION] button to enter the function mode, and use the [DATA] knob to select "F24".



Press the [SELECT] button to confirm, and use the [DATA] knob to choose the memory: L01~L08. then Press [SELECT] button again to confirm.

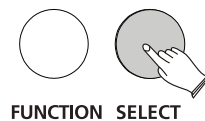

Press the [FUNCTION] and [SELECT] buttons simultaneously to restore the default Setting:L01.

## Saving Memory Data

Press the [FUNCTION] button to enter the function mode, and use the [DATA] knob to select "F25".



Press the [SELECT] button to confirm, and use the [DATA] knob to choose the memory: E01~E08. Then press [SELECT] button again to confirm.

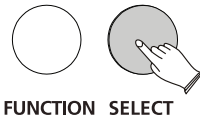

Press the [FUNCTION] and [SELECT] buttons simultaneously to restore the default Setting:E01.

## Selecting Lesson Track

Press the [FUNCTION] button to enter the function mode, and use the [DATA] knob to select "F26".



Press the [SELECT] button to confirm, and use the [DATA] knob to set the track: L-r/L-L.

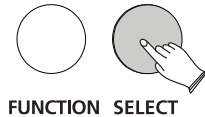

L-r: Right Hand

L-L: Left Hand

## Selecting Lesson Group

Press the [FUNCTION] button to enter the function mode, and use the [DATA] knob to select "F27".



Press the [SELECT] button to confirm, and use the [DATA] knob to set the lesson group: L-b/LC3/LC4/L-S.

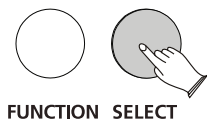

## Grading

When this function is engaged, after playing play-along songs, your instrument will grade your performance within the range of 0~100.

Press the [FUNCTION] button to enter the function mode, and use the [DATA] knob to select "F28".



Press the [SELECT] button to confirm, and use the [DATA] knob to set On/Off.

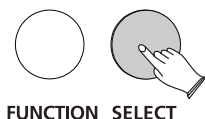

Press the [FUNCTION] and [SELECT] buttons simultaneously to restore the default setting: On.

## Pedal 1 (Sustain Pedal) Control

Press the [FUNCTION] button to enter the function mode, and use the [DATA] knob to select "F29".



Press the [SELECT] button to confirm, and use the [DATA] knob to choose: nor: Normal, P-1:load mem.

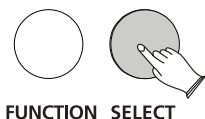

Press the [FUNCTION] and [SELECT] buttons simultaneously to restore the default setting: nor: sus.

P-1-Mem-----After "Memory" selected, step the pedal and the LED will display the current Registration Memory set, such as "L01". Now use the [DATA CONTROL] knob to select your desired Registration Memory set: L01~L08. Press the [ENTER] button before the LED stops flashing to load the setting data.

If you want to change the current Registration Memory, please refer to Page 24~25.

### Pedal 2 (Sostenuto Pedal) Control

Press the [FUNCTION] button to enter the function mode, and use the [DATA] knob to select "F30".



Press the [SELECT] button to confirm, and use [DATA] knob to choose: nor: Normal, P-1:load mem.

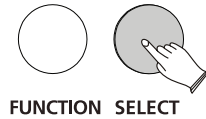

Press the [FUNCTION] and [SELECT] buttons simultaneously to restore the default setting: nor: sos.

### Pedal 3 (Soft Pedal) Control

Press the [FUNCTION] button to enter the function mode, and use the [DATA] knob to select "F31".



Press the [SELECT] button to confirm, and use the [DATA] knob to choose: nor:Normal, P-1:load mem.

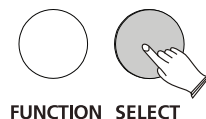

Press the [FUNCTION] and [SELECT] buttons simultaneously to restore the default setting: nor: soft.

## Off time setting

Press the [FUNCTION] button to enter the function mode, and use the [DATA] knob to select "F32".



Press the [SELECT] button to confirm, and use the [DATA] knob to set the off time: 20~60 min (0 min: Cancel).

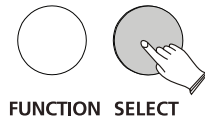

Press the [FUNCTION] and [SELECT] buttons simultaneously to restore the default value: 30 min.

## Factory Reset

Press the [FUNCTION] button to enter the Function Mode, and use the [DATA] knob to select "F33", press the [ENTER] button to confirm. Then press the [SELECT] button again to restore all functions to factory defaults. (The parts with asterisk in function menu are not included)



## Touch

Press the [FUNCTION] button to enter the Function Mode, and use the [DATA] knob to select "F34".



Press the [SELECT] button to confirm, and use [DATA] knob to L-1/L-2/nor/h-1/h-2/OFF.

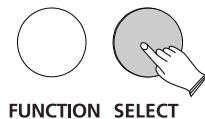

Press the [FUNCTION] and [SELECT] buttons simultaneously to restore the default setting: nor.



# Song Recording

## Record

Your instrument has perfect Record function with 5 individual tracks to help record your performance and make perfect songs.

Press the [RECORD] button and the LED will display: rE1. Then use the [DATA] knob to select your desired Track (rE1~rE5) and play the keyboard to start recording.

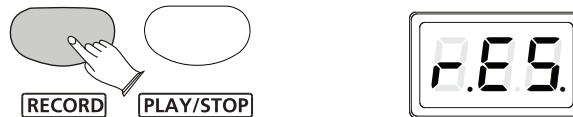

### NOTE

*If the display shows r.E1. after one track selected, it indicates that there are recording data stored in the track.*

To stop recording, press the [RECORD] button again.

## Playback

Press the [PLAY/STOP] button to enter Playback mode. Use the [DATA] knob to select the track to playback. Then press the [PLAY/STOP] button again to playback. If you setting is to playback all the tracks and the LED will display "ALL". (If you enter the Playback mode just after one track recorded, the track will be automatically selected as the current track to playback.)



## Delete

Press [PLAY/STOP] button. Then use the [DATA] knob to select the track of which you want to delete the data. Then long press the [RECORD] button until the LED display "cLr" which indicates the data recorded on the track is deleted.



# Teaching Function

The Learning Function can help the beginner to learn to play some famous songs. Audition: press the [DEMO/EDU] button and then use the [DATA] knob to select the desired song(b01~b99~106, C01~C30, C01~C40, S01~S45).

## Learning Mode

Hold down the [DEMO/EDU] button until the indicators of [PLAY/STOP] and [DEMO/EDU] buttons flash. The LED will display: L-1. You may press the [DEMO/EDU] button to select the Learning mode L-1, L-2 and L-3. Then use the [DATA] knob to select the song to learn.

To start learning, press the [PLAY/STOP] button again.



## 1.3-Step Learning

### Step 1:

Press the [DEMO/EDU] button repeatedly to enter the Step 1 mode to learn the skill of playing with bands. In the mode, the learning song works as the band to accompany your performance. You have to keep playing with the rhythm of the learning song. If you stop playing for over 5 seconds, the current Left/Right part melody will automatically play.



### Step 2:

Press the [DEMO/EDU] button to enter the Step 2 mode to learn the rhythm of learning songs. When you play one key on the keyboard, the learning song will play according to your rhythm. The note you play is not required to be consistent with the learning song. You can even keep playing one key to continue the learning song.



### Step 3:

Press the [DEMO/EDU] button repeatedly to enter the Step 3 mode to learn to correctly play learning songs. In the mode, when you play the keyboard, the learning song will accompany your performance. If you play the wrong note, the learning song will stop until you play the correct note.



---

## Automatic Scoring

After you finish learning one song, your instrument may automatically score 0 to 100 on your performance. If you want to turn off the automatic scoring function, please refer to the instructions on Page 26.

---

## Left/Right Part Learning

The default setting is Right part learning. If you want to shift to Left part learning, please refer to instructions on Page 25.

---

## Exit the Learning Mode

To exit the Learning Mode, press the [DEMO/EDU] button repeatedly. If you want to exit the learning mode during learning, press the [DEMO/EDU] button.

# Factory Set

1. Turn off the power.



2. Hold down the [FUNCTION] and [SELECT] buttons, then turn the power on. It can restore all functions to factory defaults.



# Appendix

## Normal Voice List (16)

No.	Sound Name
1	Grand Piano
2	Bright Piano
3	E. Piano 1
4	E. Piano 2
5	Vibes
6	FM EP
7	Rock Organ
8	Church Organ
9	Harpsichord
10	Clav
11	Strings
12	Choir
13	Fantasia
14	Warm Pad
15	Upright Bass
16	Electric Bass



## Troubleshooting Hints

<ul style="list-style-type: none"> <li>• It may cause noise when you use mobile phone near the keyboard</li> </ul>	<p>It will produce radiation when you use mobile phone near the electronic keyboard. Please shut down the mobile phone or use it away from the keyboard to prevent the radiation</p>
<ul style="list-style-type: none"> <li>• Not all of the voices seem to sound, or the sound seems to cut off.</li> </ul>	<p>The instrument is polyphonic up to a maximum of 32 notes — including Dual voice, Split Voice, auto accompaniment, song, and Metronome. Notes exceeding this limit will not sound.</p>
<ul style="list-style-type: none"> <li>• The Auto Accompaniment does not sound properly.</li> </ul>	<p>Make sure that the Auto Accomp Volume Function is set to an appropriate level. Is the Split Point set to an appropriate key for the chords you are playing? Set the Split Point to an appropriate position on the keyboard.</p>
<ul style="list-style-type: none"> <li>• No sound produced by the keyboard, but the lights and screen work.</li> </ul>	<p>Check that the master volume control is not set to minimum. Check that nothing is plugged into the headphone socket.</p>
<ul style="list-style-type: none"> <li>• The sound of the voice changes from note to note.</li> </ul>	<p>This is normal. The digital tone generation uses multiple recordings (samples) of an instrument across the range of the keyboard; The actual sound of the voice may be slightly different from note to note.</p>
<ul style="list-style-type: none"> <li>• The volume is too soft.</li> <li>• The sound quality is poor.</li> <li>• The rhythm stops unexpectedly or will not play.</li> <li>• The recorded data of the song, etc. does not play correctly.</li> <li>• The LED display suddenly goes dark, and all panel settings are reset.</li> </ul>	<p>If you have lost or damaged your AC adaptor, please contact your nearest store for a correct replacement adaptor. An incorrect AC mains adaptor which is not rated sufficiently can cause malfunction or damage.</p>
<ul style="list-style-type: none"> <li>• To completely restore all settings as per factory settings</li> </ul>	<p>Perform a factory reset, Please refer to content in this owner's manual. All of the user setting will be erased and the default factory settings will be applied to the instrument.</p>
<ul style="list-style-type: none"> <li>• Power suddenly and unexpectedly turns off, after a period of not touching the keys.</li> </ul>	<p>This is normal and the Auto Power Off function may have been activated. If you need to disable the Auto Power Off function, please see how to do this in the owner's manual.</p>
<ul style="list-style-type: none"> <li>• The sustain pedal or footswitch seems to produce the opposite effect. Example pressing the footswitch deactivates the sustain, and releasing the footswitch triggers the sustain.</li> </ul>	<p>The polarity of the footswitch needs to be correctly detected. Make sure the jack plug for the footswitch is connected. Switch the instrument on whilst not touching the pedal.</p>



## Specifications

<b>Keyboards:</b>	88 standard-size hammer keys with touch response
<b>Display:</b>	LED display
<b>Polyphony:</b>	32 notes max
<b>Voices:</b>	16+112
<b>Voice Control:</b>	Layer, Touch, Tune, Split, Tempo, Grand Piano
<b>Effect:</b>	Reverb type (8) Chorus type (13)
<b>Keyboard Control:</b>	Split, DUO Piano
<b>Demo:</b>	50 Songs+221 Learning songs (b01~b99~106, C01~C30, C01~C40, S01~S45)
<b>Song Recording:</b>	Real time record and playback
<b>Interface:</b>	Headphone Jack X2, Line In/Out, USB to Host
<b>Dimensions :</b>	1362(W)*440(D)*855(H)mm
<b>Weight:</b>	43.5Kg

## Assembly Instruction

### What is Included?



Cylindrical Nuts(A) X4

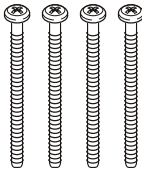

Foot Bolts(B) X4



Piano Body Bolts(C) X2



Back Panel Bolts(D) X2

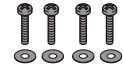

Back Panel Screws(E) X4

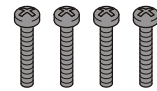

Pedal Board Bolts(F) X4



Plastic Cap(G) X2

Not pictured: Power Adapter

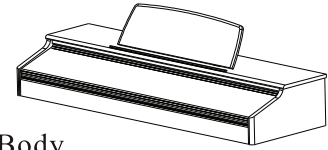

Piano Body

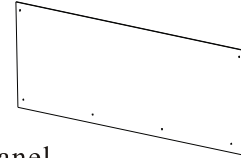

Back Panel

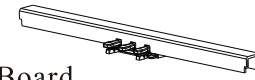

Pedal Board



Legs(2)



Feet(2)

### 1. Assembling the Stand Legs

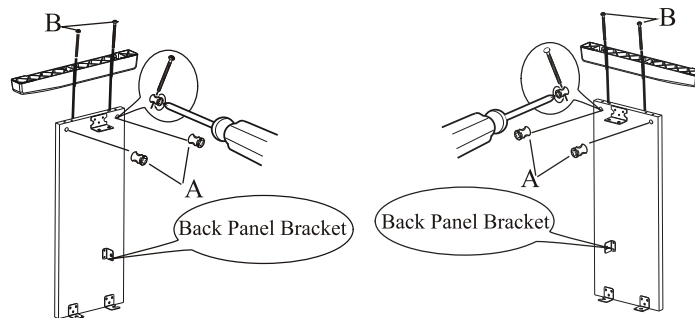

Place the four Cylindrical Nut (A) into the holes in the stand Legs. With the Phillips slot facing out. Use a screwdriver to align the threads in the nuts with the openings on the bottom of the Stand Legs.

Place the dowells in the feet into the appropriate holes in the bottom of the Stand Legs. Make sure that the feet are facing away from the back panel bracket as shown below. Thread two Foot Bolts (B) through the foot and into the cylindrical washers, rotating the washer to align if needed. Firmly tighten and repeat for the other side.

## 2. Attaching the Pedal Board

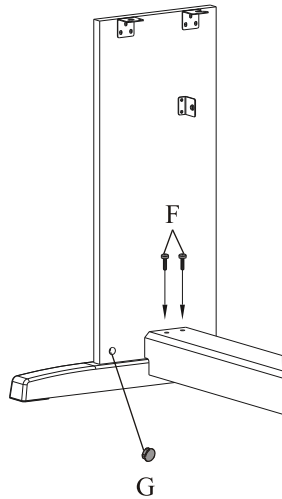

Starting with the right Stand Leg, align the holes in the Pedal Board with the holes in the Pedal Board Bracket as shown. Make sure that the pedals are facing towards the front of the Stand Legs.

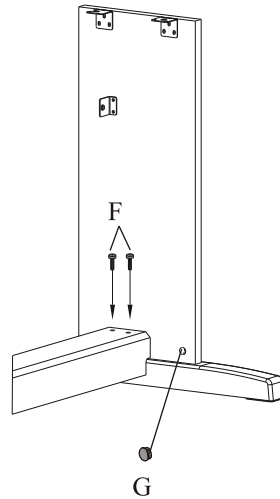

Thread two Pedal Board Bolts (F) through the Pedal Board and into the bracket. Repeat with the left Stand Leg and tighten all bolts fully. Place the four Plastic Caps (G) over the Cylindrical Nut openings.

## 3. Attaching the Back Panel and Piano Body

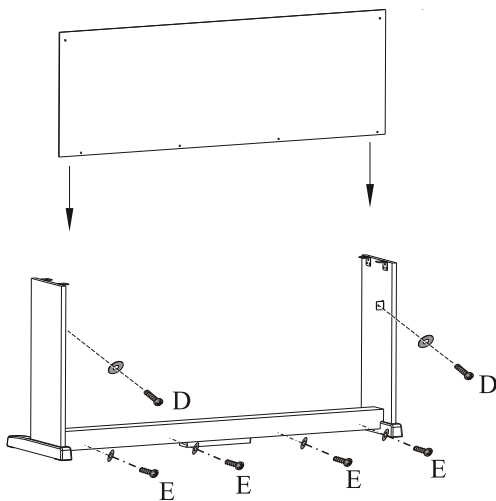

Using two Back Panel Bolts (D) with washers, and four Back Panel Screws (E) with washers, attach the Back Panel to the stand. Please note that the pedal board is not predrilled for the Back Panel Screws, and they must be driven in manually.

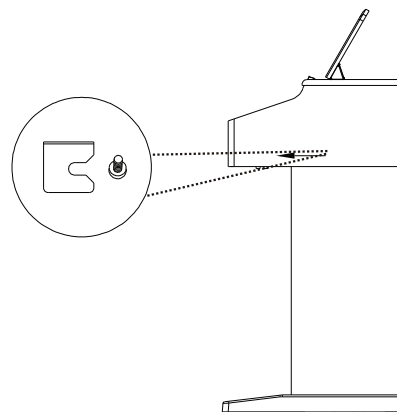

With help from another person, lift the piano onto the stand and slide forwards, pushing the guide rods on the bottom of the piano into the slots on the Stand Legs, as shown below.

### PLEASE NOTE

When lifting the piano onto its stand, be careful not to catch/trap hands or fingers.

#### 4. Securing the Piano Body

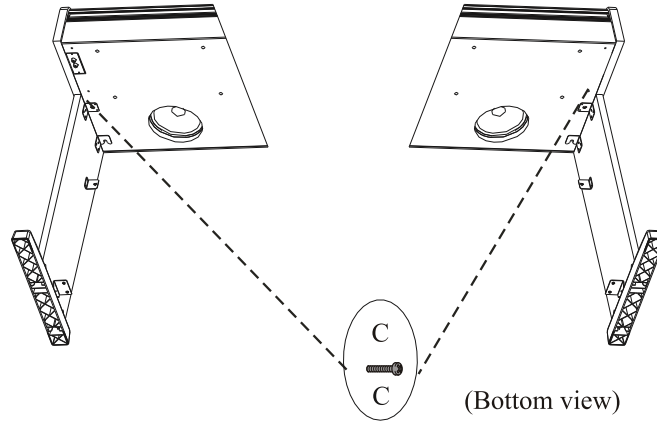

Finish attaching the piano to the stand by using the two Piano Body Bolts (C) to attach the bottom of the piano to its stand.

#### 5. Connecting the Pedal Cable and Power Supply

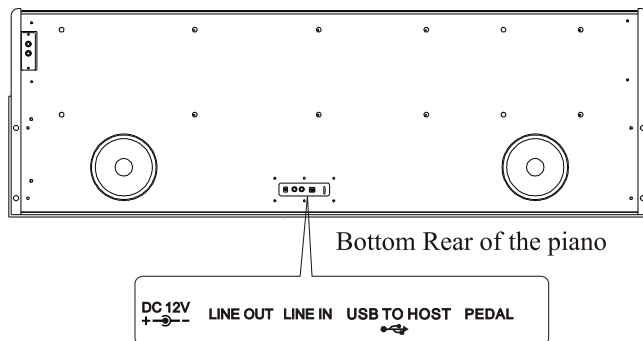

Attach the DC Power Cord and Pedal Cable into their connectors on the bottom of the piano as shown.

## FCC STATEMENT

1. This device complies with Part 15 of the FCC Rules. Operation is subject to the following two conditions:
  - (1) This device may not cause harmful interference.
  - (2) This device must accept any interference received, including interference that may cause undesired operation.
2. Changes or modifications not expressly approved by the party responsible for compliance could void the user's authority to operate the equipment.

NOTE: This equipment has been tested and found to comply with the limits for a Class B digital device, pursuant to Part 15 of the FCC Rules. These limits are designed to provide reasonable protection against harmful interference in a residential installation. This equipment generates uses and can radiate radio frequency energy and, if not installed and used in accordance with the instructions, may cause harmful interference to radio communications. However, there is no guarantee that interference will not occur in a particular installation. If this equipment does cause harmful interference to radio or television reception, which can be determined by turning the equipment off and on, the user is encouraged to try to correct the interference by one or more of the following measures:

- Reorient or relocate the receiving antenna.
- Increase the separation between the equipment and receiver.
- Connect the equipment into an outlet on a circuit different from that to which the receiver is connected.
- Consult the dealer or an experienced radio/TV technician for help.

## NOTES

---

## NOTES

---

**KURZWEIL**

**HDC** YOUNG CHANG  
MUSIC

196, Bongsu-daero, Seo-gu,  
Incheon, Korea