

X2

The Heavyweight
Uncompromised High-End

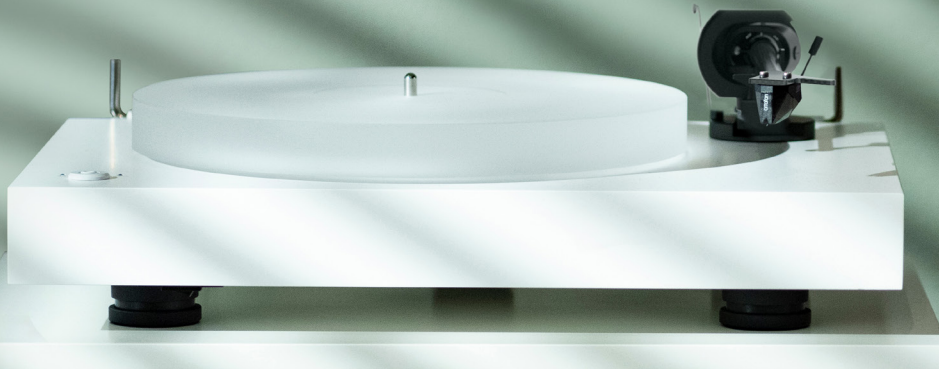

Uncompromised High-End Design - Incredible and Unparalleled Value

n/c MSRP 999 € (incl. VAT)

Pick it 2M Silver MSRP 1099 € (incl. VAT)

- Electronic speed control with 33/45 rpm speed change, which acts as "Speed Box" with ultimate speed stability
- Electronically regulated precision motor with improved damping construction for the least amount of vibration and noise
- Sub-platter with extremely low 0.001mm bearing tolerances
- Stainless steel platter-bearing with soft bronze bushing and teflon mirrors for lowest rumble and noise, and a stable, accurate speed transmission
- 9" one-piece tonearm tube with best internal damping by the ultra rigid carbon/alu sandwich construction
- TPE damped counterweight reduces arm-cartridge resonances by 50%
- Azimuth and VTA adjustment
- Pick it 2M Silver super fast, super precise MM cartridge with silver coils
- Resonance free, 2 kg heavy acryl platter
- Heavy, 50mm thick, highest quality CNC'd MDF chassis
- Luxury 8 layers of painting and hand-polished finish or real-wood, satin-waxed veneer
- Super shielded, semi-symmetrical, low-capacitance phono cables - purpose designed by Pro-Ject
- Hight adjustable, alu machined, vibration absorbing feet
- Handmade in Europe

Wood finish: 

Satin color options:  

High-gloss color options: 

Speed: 33, 45, 78 (electronic speed change)

Drive principle: belt drive

Platter: 30mm thick acryl, 2 kg heavy acryl

Mains bearing: stainless steel

Speed variance: 33: +/-0,25%; 45: +/-0,20%

Wow and flutter: 33: +/-0,12%; 45: +/-0,10%

Signal to noise: 70dB

Tonearm: 9" carbon/aluminium sandwich tonearm

Effective tonearm length: 9"/230 mm

Effective tonearm mass: 13,5 g

Overhang: 18 mm

Tracking force: 0 - 30mN (18mN recommended for Pick it 2M Silver)

Included accessories: 15V DC / 800 mA power supply, dust cover, Connect it E Phono RCA cable, felt mat

Power connection: 110 - 240 V, 50/60 Hz

Power consumption: 4.5 W max / 0.3 W standby

Dimensions: 460 x 150 x 340 mm (WxHxD) lid closed

Weight: 10 kg

Luxurious turntable configuration

In 1991 Pro-Ject started a revolution in HiFi with the introduction of the Pro-Ject 1 turntable. A new high-end, low budget turntable at the time when CD was king. Against all odds, we were creating interest in analogue audio at a time when others were turning their backs, and the success was down to three critical philosophies:

- Simple yet technically correct design
- High-quality valuable materials
- Fully handcrafted, expert engineers, made in the EU

This turntable design, with our underlying core philosophy and dedication to quality music performance, has all the high-end aspects built in that really take vinyl listening to the ultimate heights. But as is the way in hi-fi many people still wanted more. They were willing to invest more, because this is how much they fell in love with their newfound passion. It is hard to improve on such a well performing turntable, but there are ways to do it. It was not time to reinvent the wheel, because the core engineering on the P1, or now the X1, already was and still is perfect. Instead we improved on the technologies that had previously been established:

- The raw materials used in production are of a much higher quality but also more difficult to source.
- The selected components are bigger, heavier, more massive and robust for improved performance and greater build quality.

Not many companies are willing to go this extra mile, because it is a hard step to take and - as always - needs to be carefully balanced with cost vs. reward. Making the wrong decisions can lead to diminishing returns fast.

We want the X2 to lift the incredibly high standards, as set by its smaller brother the X1, to new limits. The X2 is made for those who take great joy in the fine details, the build-quality, the high-grade materials and even more audio performance.

More mass in the chassis, platter and tonearm:

Structurally, the X2 is supported by its large, heavy, dense and stiff MDF structure, reducing unwanted resonances to almost imperceptible levels. By adding this extra mass, the X2 is even quieter, allowing the vinyl reproduction to become more detailed and precise. Inside, it houses a sophisticated DC/AC generator board which, combined with the convenient speed control board, delivers clean and stable power to the silent motor system.



The tonearm is longer - 9" in length - and the tube has a wider diameter and the carbon/aluminium sandwich construction results in better internal damping. This also means, the entire tonearm bearing is upgraded to compensate for the extra mass; altogether tracking will be more precise, stable and accurate. The increased mass makes the tonearm an excellent fit for low compliance MC cartridges. The one-piece design avoids vibrations caused by detachable headshells. The TPE damped counterweight reduces arm-cartridge resonances by as much as 50%.

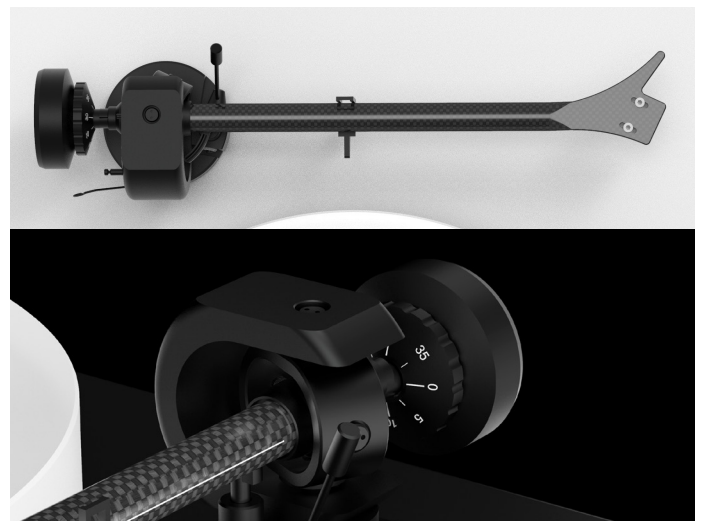

Precision tuned motor isolation:

A good motor by itself, is already very quiet. To get the best performance out of it, we have improved the motor suspension. This will allow the motor to run stable and free from outside influences. Remaining vibrations are damped and eliminated, so they are not transmitted onto the chassis, platter and cartridge. The X2's motor chassis is carefully balanced and suspended on a precision tuned TPE belt; this way the motor chassis is effectively decoupled from the main plinth for optimal performance. It is free floating, horizontally completely level and able to operate at the highest performance levels.

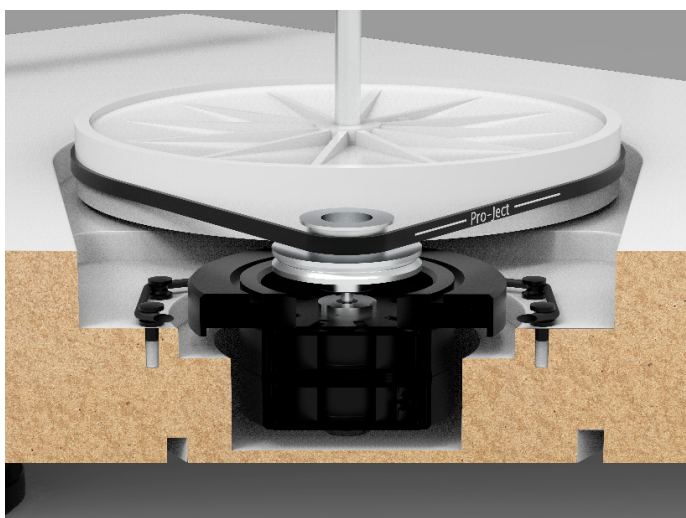

High-end Cartridge:

The X2 is packaged to suit anyone who cares about how their vinyl sounds. Supplied either with or without an Ortofon 2M Silver cartridge, average retail at 199€.



Better Audiophile Features:

Full aluminium tonearm base instead of a cheap plastic flange for better and stiffer fixing to the chassis with Azimuth and VTA adjustment.

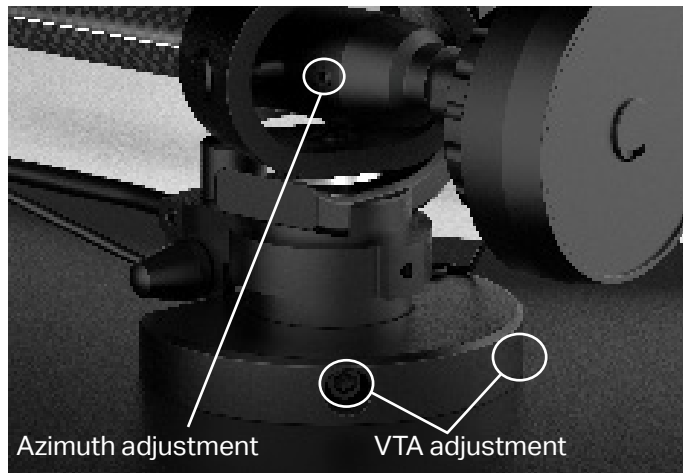

Better Feet:

Height adjustable, isolating Alu/TPE sandwich feet.



Better Cable:

All our turntables come with a high-quality phono RCA-cable. Our Connect it E is a semi-balanced, low-capacitance cable, with superior shielding. Compared to other digital and analog music sources, the signal coming from a turntable cartridge is very fragile in nature and cheap RCA cables often do not provide the ideal conditions for getting a phono signal to an amplifier. The Connect it E is purpose-designed for this exact application.

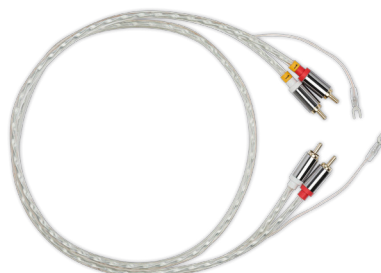



Walnut



High gloss Black



Satin Black



Satin White

The design is carefully tuned to offer the most critical features for the best price and everything is put together with Pro-Ject's decade long experience in making the best-performing turntables without blowing the budget:

MDF is 2-3 times more expensive than standard particle boards, not to mention a plastic chassis, but sounds and feels way better.

The X2's luxury 8 layers of painting and the hand-polished finish are 3-4 times more expensive than simple foils. Inside, it houses a sophisticated DC/AC generator board which, combined with the convenient speed control board, delivers clean and stable power to the quiet-running motor.

This adds additional cost, but performs many times better than a simple, direct powered AC motor. For even further improved performance, the motor is decoupled from the main plinth using a new motor suspension system.

In the X2, the motor drives a new, heavy, non-resonant Acryl platter via a sub-platter drive system and a premium grade main bearing for liquid smooth rotation. This is the perfect platform on which to place your precious vinyl records, guaranteeing absolute reliability in its performance and sonic character.

The X2 is also better than its predecessors thanks to the super-stiff, perfectly tempered Carbon/Alu sandwich construction tonearm. This 9" tonearm design is incredibly light and stiff, with improved resistance to external interference. Finished as a one-piece, with no resonance-inducing headshell, the X2 can also be set for azimuth and VTA adjustment, offering the flexibility that so many people are asking for, especially in this and even lower price ranges.

The tonearm is then supplied with a TPE-damped counterweight, further reducing cartridge-tonearm resonances.

The X2 is packaged to suit anyone who cares about how their vinyl sounds. Supplied either with or without a premium Pick it 2M Silver cartridge, manufactured by the cartridge experts at Ortofon exclusively for Pro-Ject turntables, it can be ready to play within a few minutes of unboxing. Also supplied in the box is our Connect-IT E RCA cables, a semi-balanced, low-capacitance cable with superior shielding that's optimized for turntable use. Lastly, height-adjustable feet in their Alu/TPE sandwich construction are a very exclusive but necessary feature to level the turntable and effectively isolate it from the surface it is placed on.

The X2 has all the high-end features of modern turntable designs to maximise the music and listening experience. It is a statement and a counterpoint against other upcoming turntable designs, which go the way of offering more features but less performance.

The X2 is carefully tuned to offer only audio-focused features for the best possible price, and due to our decades-long experience in analogue technologies, it's hand-assembled by a European-based factory you can trust. Every effort has been made throughout to not cut

corners on cost or sonic ability and the end result is a highly engaging, musical turntable. The X2 proves that, since 1991, our same core philosophies are those that guarantee to make music lovers happy with every new vinyl record they take for a spin.

The X2 is available in four finishes; a premium walnut wood veneer, a luxurious black 8-layer high gloss paint, or black or white eight-layer hand-polished satin paint.

