

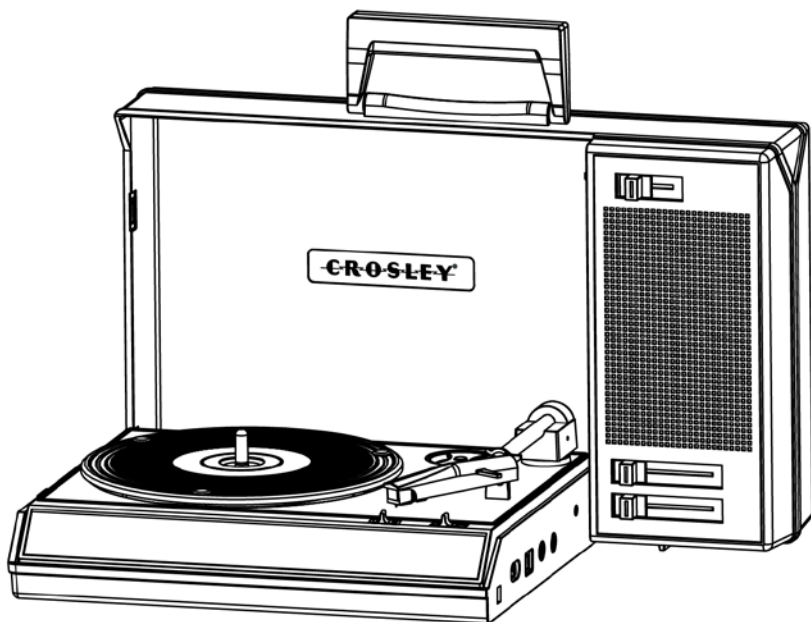

CR6016A
Spinnerette Turntable
Instruction Manual



Questions, problems, missing parts?
Before returning to the store, call Customer Service
8 a.m. – 6 p.m., EST, Monday – Friday
1-888-CROSLEY
www.crosleyradio.com

Safety Instructions

Read and understand this entire manual before using this product. Keep these instructions for future reference.

1. Do not use this product near water.
2. This product should be operated only by the type of power source indicated on the marking label or in this instruction manual.
3. Do not defeat the safety purpose of the polarized plug. A polarized plug has two blades with one blade wider than the other. This plug will fit into the power outlet only one way. If you are unable to insert the plug fully into the outlet try reversing the plug. If the plug should still fail to fit, contact your electrician.
4. Protect the power cord from being walked on or pinched particularly at plugs, convenience receptacles, and the point where they exit from the product.
5. Do not overload wall outlets, extension cords, or integral convenience receptacles as this can result in a risk of fire or electric shock.
6. Never push objects of any kind into this product through openings as they may touch dangerous voltage points or short-out parts that could result in a fire or electric shock. Never spill liquid of any kind on the product.
7. Do not attempt to service this product yourself as opening or removing covers may expose you to dangerous voltage or other hazards. Refer all servicing to qualified service personnel.
8. Changes or modifications to this unit not expressly approved by the party responsible for compliance could void the user's authority to operate the equipment.
9. Do not use attachments not recommended by the product manufacturer as they may cause hazards.
10. A product and cart combination should be moved with care. Quick stops, excessive force, and uneven surfaces may cause the product and cart combination to overturn.
11. Slots and openings in the cabinet are provided for ventilation and to ensure reliable operation of the product and to protect it from overheating. Do not block or cover these openings.
12. Unplug the product during lightning storm or when unused for long periods of time.

Items in this package

Before throwing away any packaging materials, please check thoroughly and make sure you find the following items that come along with this package:

- Turntable
- 45 RPM adapter
- 3.5mm aux in cable
- Power adaptor
- USB cable

Please contact Crosley customer service if there is any accessory missing from the package. **Retain the original packaging materials for exchange or return purposes.**

Specifications

Power	AC power adaptor, DC output 12V 1A
Power consumption	12W
Speaker	3.5", 8Ω, 5W x1
Turntable speed	33 ¹ / ₃ , 45, 78 RPM
Replacement needle	Crosley NP5

Note:

- *Design and specifications are subject to change without notice.*
- **To help save power consumption, some models will comply with ERP energy saving standard. When there is no audio input for 20 minutes, their powers will automatically cut-off. To turn power back on and resume playing, you will need to turn off the power and turn it on again.**

Product Description

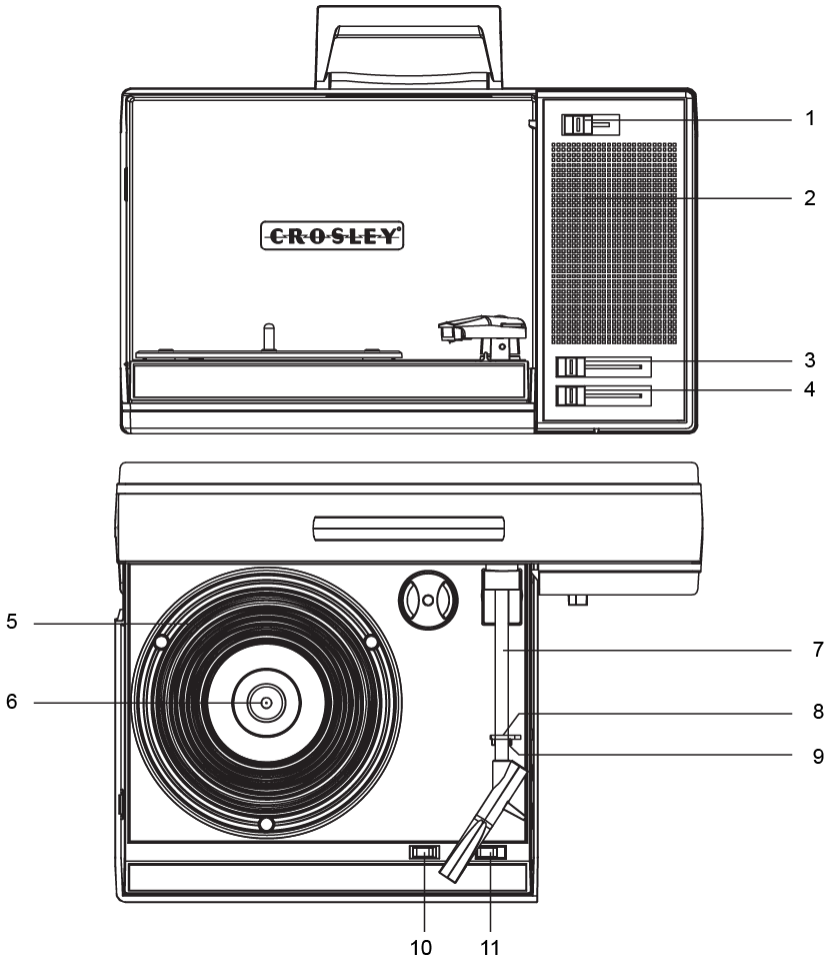

- 1. Turntable Lock
- 2. Speaker
- 3. Volume Control
- 4. Tone Control
- 5. Turntable Platter
- 6. Turntable Spindle

- 7. Tonearm
- 8. Hold Down Clip
- 9. Tonearm Rest
- 10. Auto-stop Switch
- 11. Speed Switch

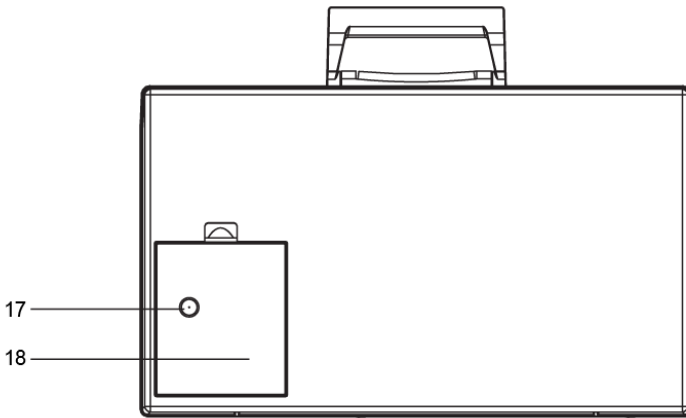
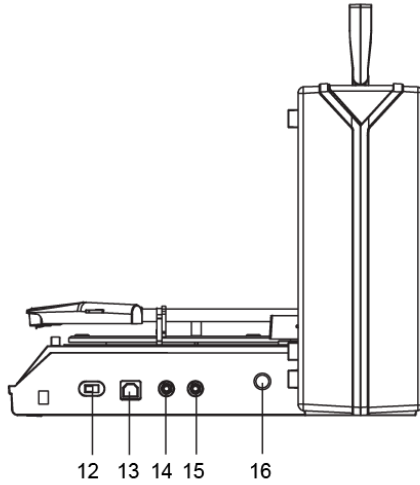

12. Function Switch

14. Aux in Jack

15. Headphone Jack

16. Auto-stop Adjustment Hole

13. USB Jack

17. Power Jack

18. Power Adapter Compartment

19. 45 RPM Adapter

Initial Setup

Essential Setup

1. Slide the **Turntable Lock** to the right to release the turntable deck and place the turntable on a flat and level surface. The selected location should be stable and free from vibration.
2. Remove the tie-wrap that is holding the tonearm.
3. Connect AC adaptor to the **Power Jack** of the unit.

Note: Do not plug the AC power adaptor to power outlet before all the assembly is completed. Before turning the power on, make sure again all the connection settings are correct. Always turn off the power when connecting or disconnecting.

Aux Input Connection

You can connect an audio device to this unit and play your music through its speakers. To do this, set the **Function Switch** to the Aux mode, and connect the 3.5mm auxiliary cable between your audio device and the **Aux In Jack** of this unit and start playing.

Turntable Operation

1. Set the **Function Switch** to PHONO position.
2. Set the **Speed Switch** accordingly.
3. Place the record on the turntable. Use the **45 RPM Adapter** if necessary.
4. Remove the stylus protector from the stylus assembly.

Note: To avoid stylus damage, make certain the included stylus guard is in place whenever the turntable is being moved or cleaned.

5. Release the tonearm **Hold Down Clip**.
Note: when the turntable is not in use, remember to lock back hold down clip.
6. Lift up the **Tonearm** and move it over the record where play is desired to begin. Gently put down the **Tonearm** and begin the playback.
7. When the record is finished playing, gently lift up the **Tonearm** and move it back to the **Tonearm Rest**.
8. Lock the **Hold Down Clip** to secure the tonearm.

Tone Control

Slide the Tone Control can adjust the treble level of the turntable.

Platter Auto-stop

If the **Auto-stop Switch** is set to ON position, the platter will stop spinning automatically when the record plays to the end. In some rare occasion, if the turntable stops playing before the end of the record, set the switch to OFF position the turntable should overcome this issue.

Adjustment if Tonearm Stops too early

If the platter stops before the tonearm reaches the end of the record, you can adjust it by following the below steps:

1. Disconnect the turntable from the power supply.
2. Insert a screwdriver into the **Auto-stop Adjustment Hole** and locate the tuning screw inside.
3. If the tonearm stops earlier than the end of the record, rotate the screw clockwise by approximately $\frac{1}{4}$ turn only.
4. Reconnect the turntable to the power supply.
5. Replay the record to see if the adjustment has been successful. If not, repeat steps 1-4, but only rotate slightly to perform the fine adjustment. Rotate the screw counter-clockwise if the tone arm fails to stop. Repeat this fine adjustment process until the tonearm will stop at the correct finish point.

Needle Replacement

Removing Needle

1. Gently pull down the front edge of the needle.
2. Pull needle forward.
3. Pull out and remove.



Installing Needle

1. Position the needle with its tip facing down.
2. Line up the back of the needle with the cartridge.
3. Insert the needle with its front end at a downward angle and gently lift the front of the needle upward until it snaps into place.



USB Recording

To record the vinyl into digital file formats such as MP3, you can use the **USB Output Jack** to connect this unit to your computer's USB port and use the recording program of your choice.

1. Use the supplied USB cable to connect the unit to your computer.
2. Turn on the power of the turntable.
3. Run the recording program of your choice.

Note:

- *In case you do not have a recording program installed, Audacity is a free software to use, distributed under the GNU General Public License (GPL). For most updated version of Audacity and instructions on how to use it, please visit Audacity website: <http://www.audacityteam.org/>. Crosley would not carry responsibility or support for third party software and all downloads should be carried out at user's own responsibility.*
- *Depending on the operating system and software that you are using, you may need to make some changes on settings of the operating system and/or software before starting the recording process. As a general guideline, the recording source/input should be set to Microphone USB audio codec. And it is recommended to set it to 2 channel, 16 bit, 48000Hz (DVD Quality)*
- *Make sure the USB connection is made to the USB jack of your computer directly instead of a USB hub to ensure a successful connection.*

Turntable Maintenance

1. Do not touch the stylus tip with your fingers. Avoid bumping the stylus on the turntable mat or a record's edge.
2. Clean the stylus frequently with a soft brush with a back-to-front motion only.
3. Clean the records to get rid of dust or grease with a record cleaning brush and record cleaning solution.
4. Clean the turntable lid and turntable cabinet with a slightly dampened microfiber cloth.

Note: Do not use cleanser other that contains alcohol, benzene or any other harsh chemicals, which might damage the paint and finish of the turntable.

**** Crosley offers a product line of different cleaning accessories. Please ask your retailer or check out our website www.crosleyradio.com for more cleaning product information.**

Troubleshooting

There is no power

- Power adaptor is not connected correctly.
- No power at the power outlet.
- To help save power consumption, some models will comply with ERP energy saving standard. When there is no audio input for 20 minutes, their powers will automatically cut-off. To turn power back on and resume playing, turn off the power and turn it on again.

Power is on, but the platter does not turn

- Turntable mode is not selected.
- Turntable's drive belt has slipped off.

FCC Statements

This equipment has been tested and found to comply with the limits for a Class B digital device, pursuant to Part 15 of the FCC Rules. These limits are designed to provide reasonable protection against harmful interference in a residential installation. This equipment generates, uses, and can radiate radio frequency energy and, if not installed and used in accordance with the instructions, may cause harmful interference to radio communications. However, there is no guarantee that interference will not occur in a particular installation. If this equipment does cause harmful interference to radio or television reception, which can be determined by turning the equipment off and on, the user is encouraged to try to correct the interference by one or more of the following measures:

- Reorient or relocate the receiving antenna.
- Increase the separation between the equipment and receiver.
- Connect the equipment into a circuit different from that to which the receiver is connected.
- Consult the dealer or an experienced radio TV technician for help.